



# Semi-hermetic GEA Compressors

GEA Bock HA22e, HA34e, HA44e

# Advanced competence, in touch with you

In this brochure we present our current program of air cooled semi-hermetic GEA compressors. Always close to our customers' market and process requirements, GEA offers the right compressors for refrigeration in all commercial, industrial, and transport sectors.

You will find our semi-hermetic compressors across today's food and beverage industries, spanning the entire cold chain. In addition to many other uses, these compressors are ideally suited for refrigeration in supermarkets and food transport. Likewise, they support state-of-the-art refrigeration and air-conditioning solutions in petrochemical, chemical, pharmaceutical, marine and leisure facility applications.

We develop these compressors as a global refrigeration expert with more than a century of experience. All core components are developed, manufactured, assembled, and tested at our own facilities, always reflecting our enthusiasm for your success. Our worldwide dealer and service network is ready to show you compressors and maintenance solutions for your maximum productivity, wherever you are.

## World-leading technology from GEA

GEA is one of the largest suppliers of process technology for the food industry and for a wide range of other industries. As an international technology group, the company focuses on world-leading process solutions and components for sophisticated production processes.

Long-life, energy-efficient GEA solutions ensure both economical savings and reduced ecological footprint, to help you protect the climate and your standing with customers and authorities.

Be inspired by our state-of-the-art products and the entire passion that goes into each of our components.



<b>Introduction</b>	<b>02</b>
HA semi-hermetic GEA compressors	04
Improved technology	08
Unique features and advantages	10
<b>GEA compressors HA semi-hermetic</b>	<b>14</b>
Operating limits and performance data	16
Technical data	28
Dimensions and connections	29
Scope of supply and accessories	34
<b>GEA Service</b>	<b>40</b>

[www.pholod.com.ua](http://www.pholod.com.ua)

# HA semi-hermetic GEA compressors

Low-temperature applications place greater demands on compressors. This applies particularly to suction-gas-cooled semi-hermetic compressors. Within low-temperature applications the refrigerant mass flow is smaller and is heated up disproportionately by the drive motor. This has the following effects on the operation of the compressor:

- The volumetric efficiency is reduced due to the decreasing specific density.
- The discharge temperature and oil temperature are higher. This means that the oil ages more quickly and the lubrication properties deteriorate.

This particularly affects refrigerants with a high isentropic exponent, such as the new HFO/HFC blends with lower GWP, which are envisaged as transitional R404A replacement refrigerants.

For these refrigerants in low-temperature applications with suction-gas-cooled semi-hermetic compressors it is important that special technical measures are envisaged for reduction of the discharge temperature!

The “HA principle” of air-cooled compressors, specially developed by GEA, is the most efficient semi-hermetic solution for low-temperature applications. It employs a direct-suction compressor combined with an air-cooled drive motor. The suction gas is not heated additionally, but rather fed directly into the cylinders without diversions via the motor. A compact ventilation unit is integrated to cool the motor and provide air flow for the cylinder heads, partially cooling them as well. This solution reduces the discharge temperature, increasing capacity and extending the range of applications.

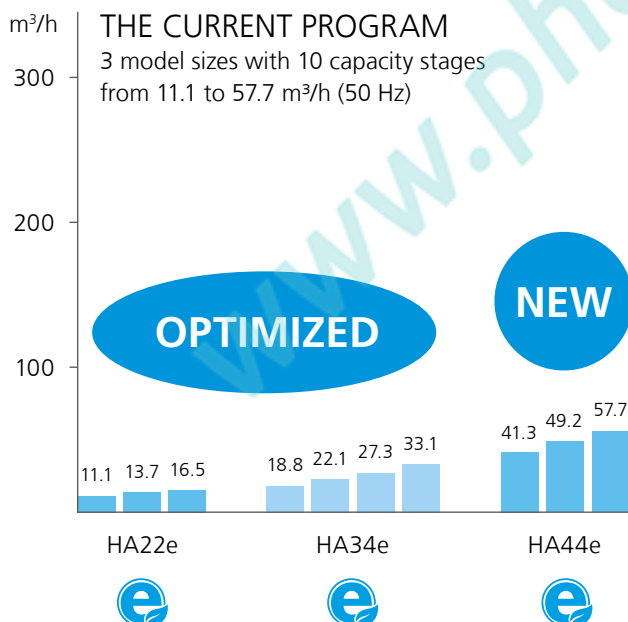

HA44e

HA vs. HG R449A discharge temperature

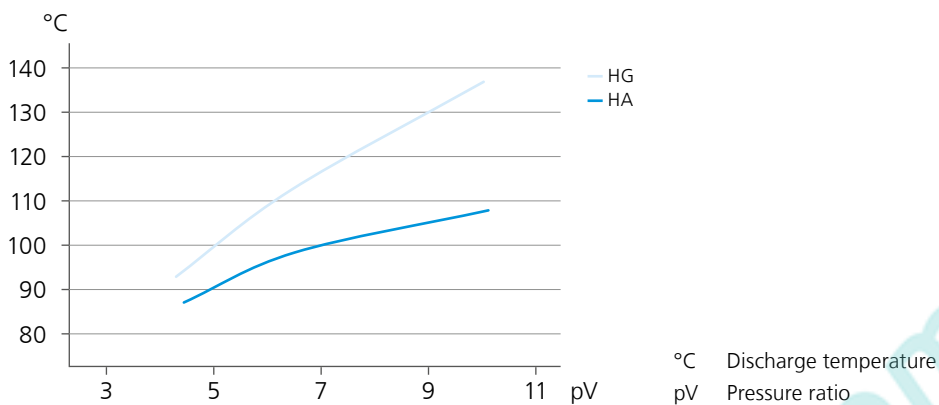

TYPE KEY

HA X 4 4 e / 465 - 4

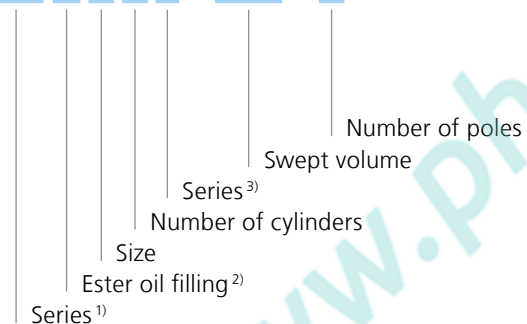

- <sup>1)</sup> HA = Hermetic Air-Cooled (low temperature application)
- <sup>2)</sup> X = Ester oil filling  
(HFC refrigerants e.g. R134a, R404A, R507, R407C)
- <sup>3)</sup> e = Additional marker for e-series compressors  
P = Additional marker for Pluscom compressors

www.pholed.com.ua

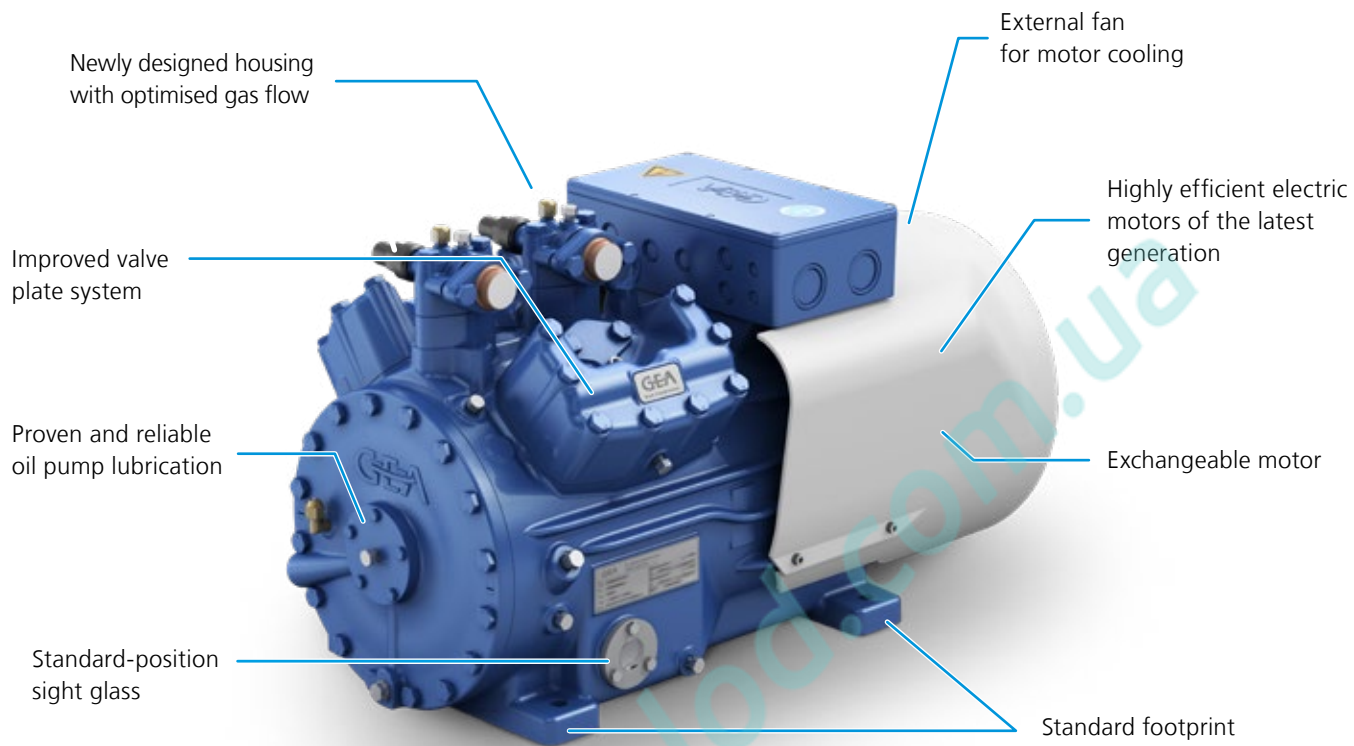

www.pholed.com.ua



HA22e



HA44e sectional drawing

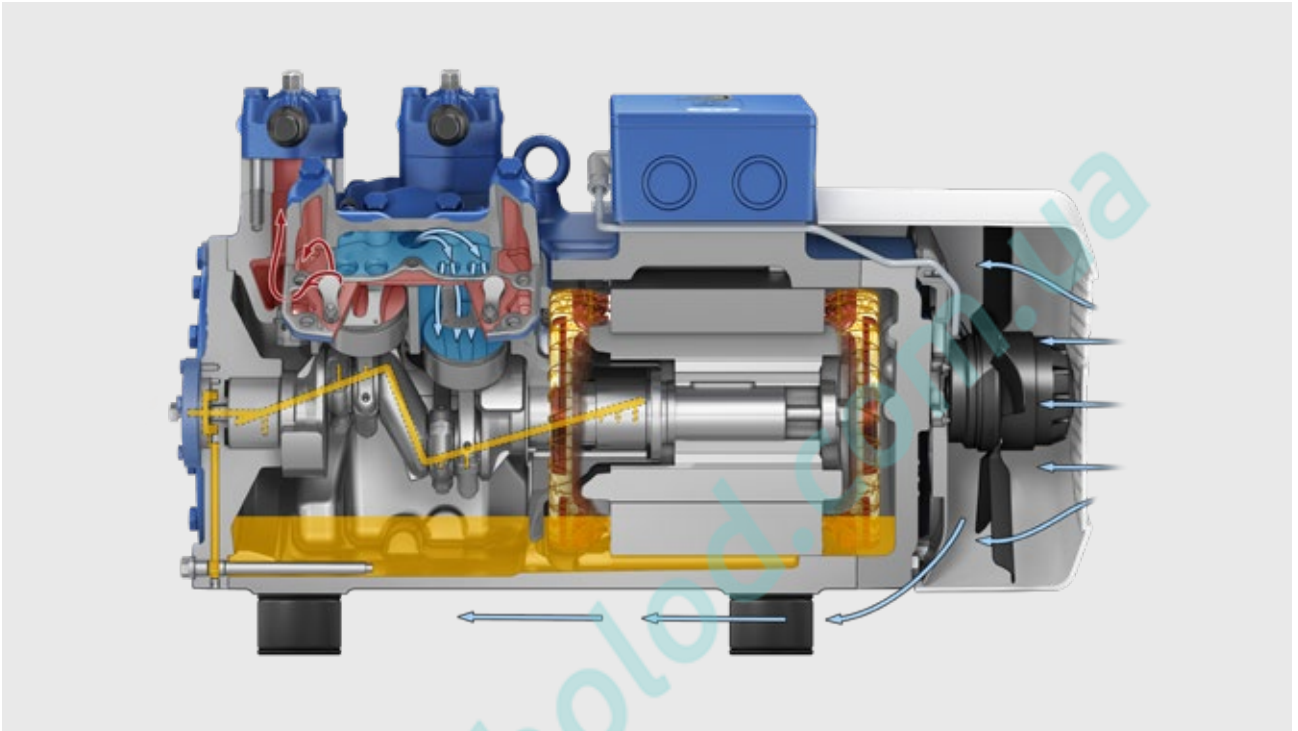

HA34e



HA44e



= efficiency

# Improved technology

## Optimized drive gear

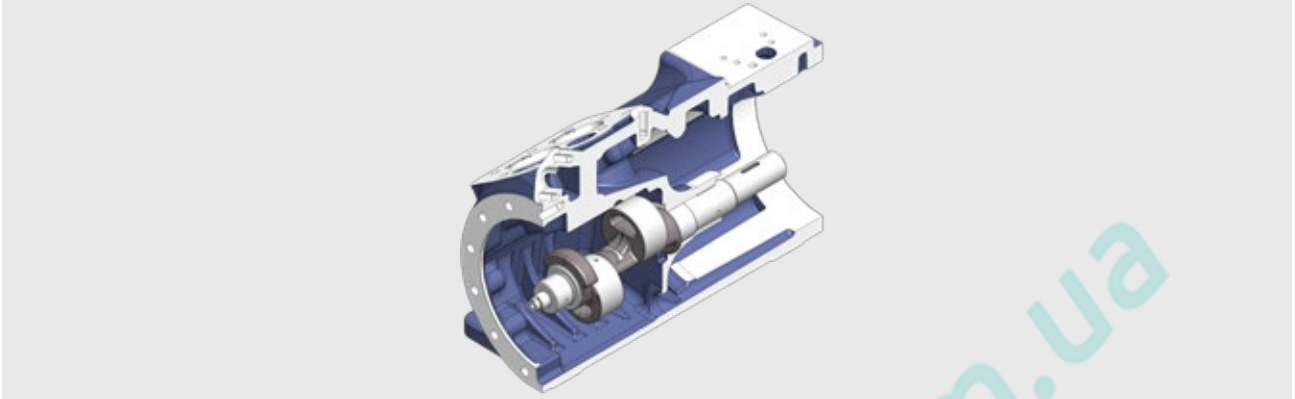

- Optimized drive gear with thrust washer, improving emergency-mode operation and resistance against damage in case of insufficient lubrication

## New, easy-to-maintain strainer

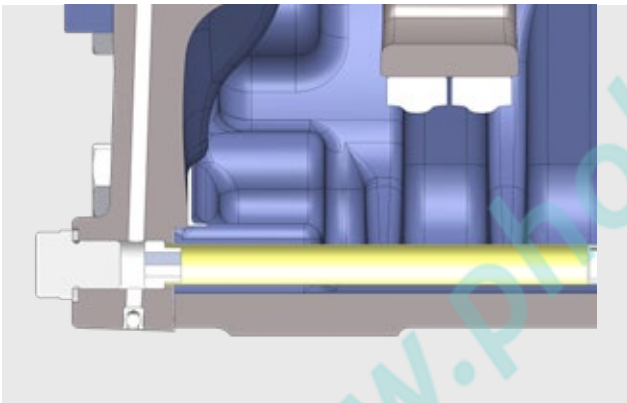

- New, easy-to-remove oil strainer for easier maintenance and increased availability

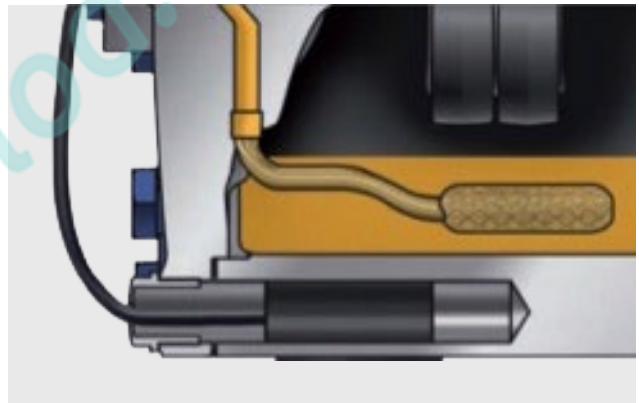

- Former version

## Optimized fastening of oil sump heater

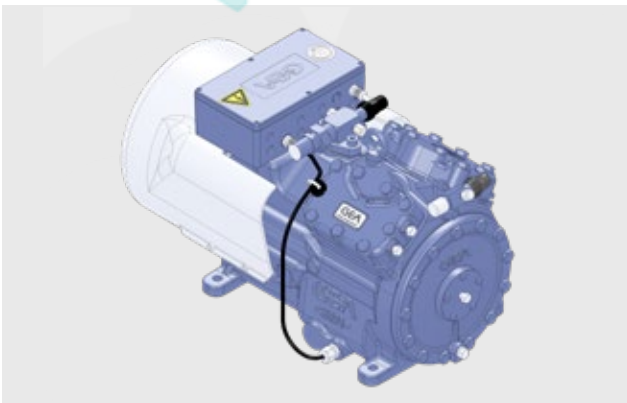

- New, optimized fastening of oil sump heater

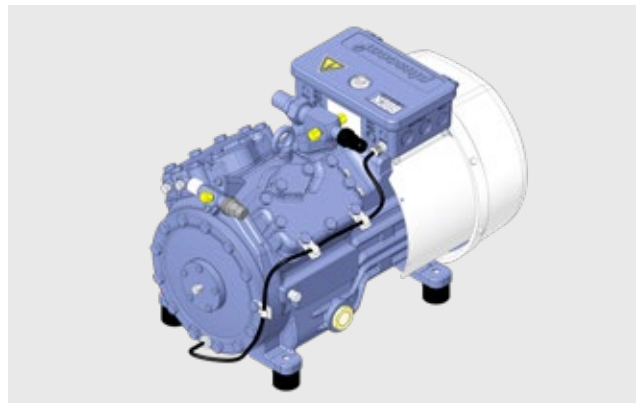

- Former version



### 50/50 winding sectioning

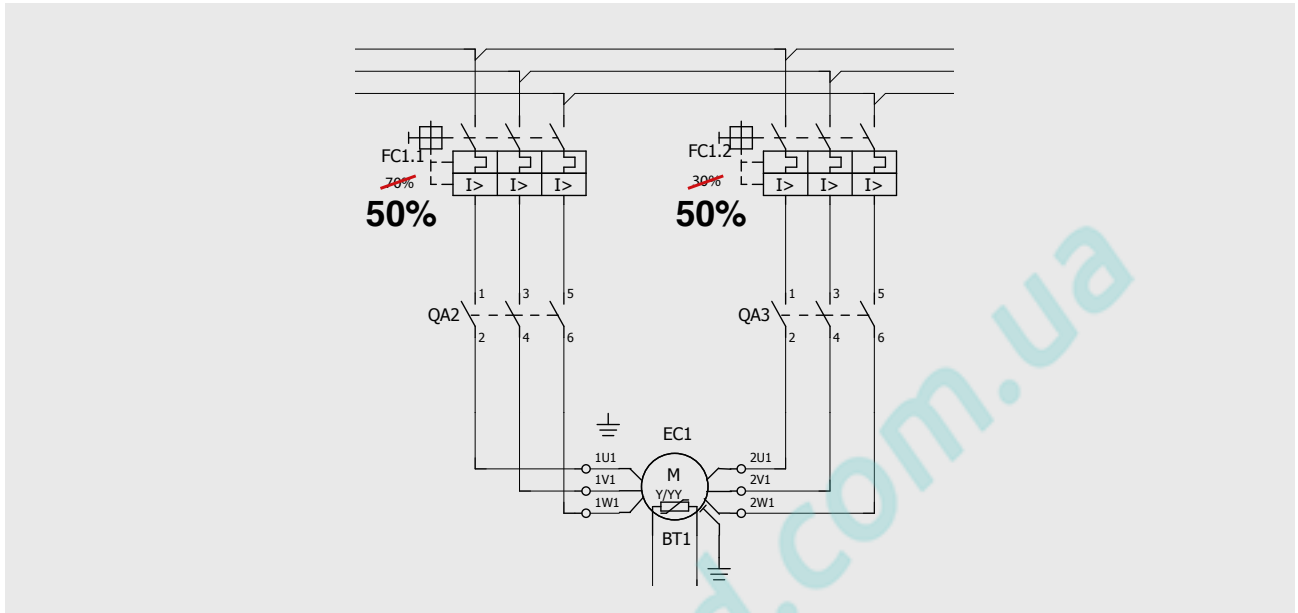

- 50/50 winding sectioning of HA44e
- State-of-the-art 50/50 Performance

### New capacity regulator (CR14 – HA34e/HA44e)

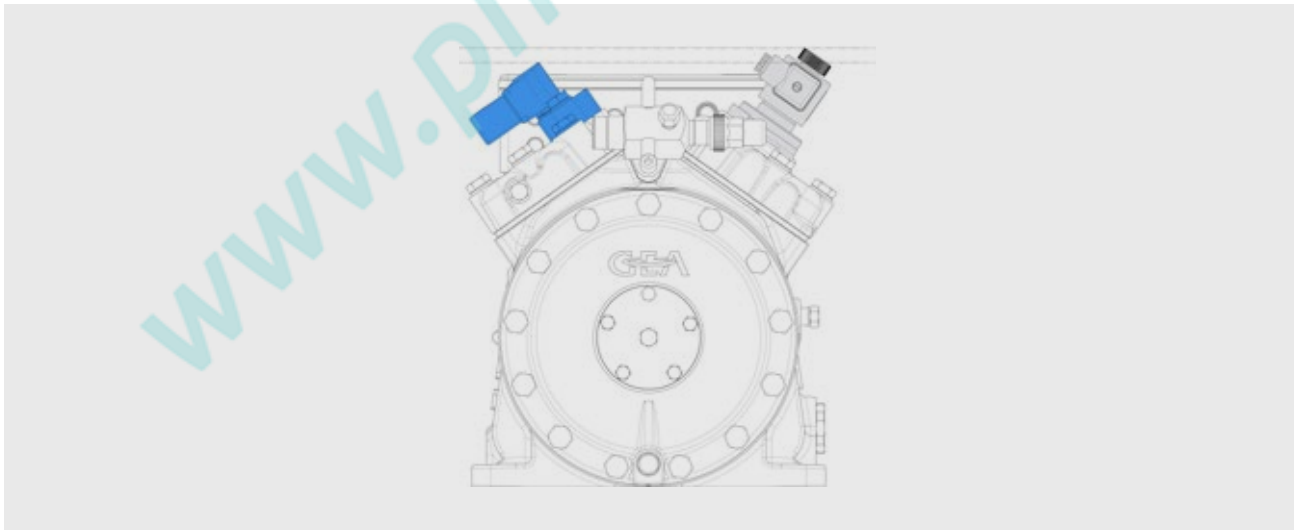

- New capacity regulator with lower height and higher operational safety due to high-pressure control

# Unique features and advantages

---

One compressor design for all standard refrigerants

---

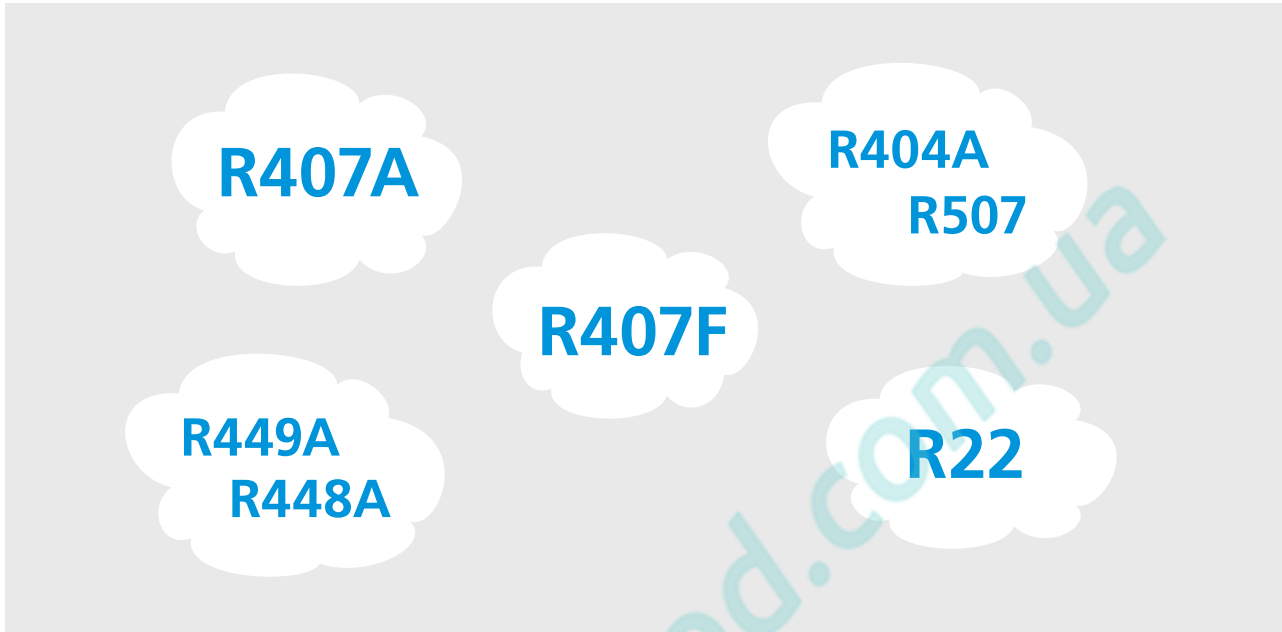

- For air-conditioning, medium and low-temperature application
- Maximum permissible operating pressure: 28 bar

---

Standard valve plate design

---

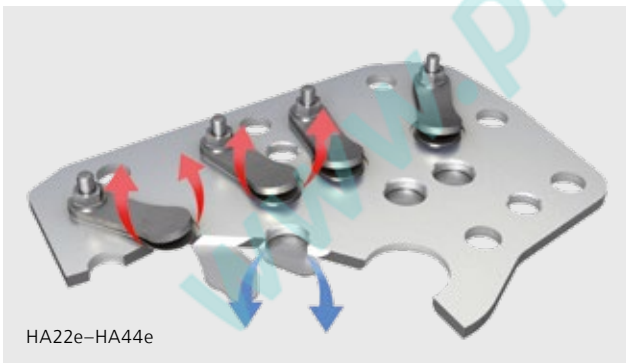

- Valves made of high-quality, impact-resistant spring steel
- Universally proven valve design with suction and discharge finger reed valves adapted to highest performance in low temperature applications

---

**Safe, reliable oil supply**

---

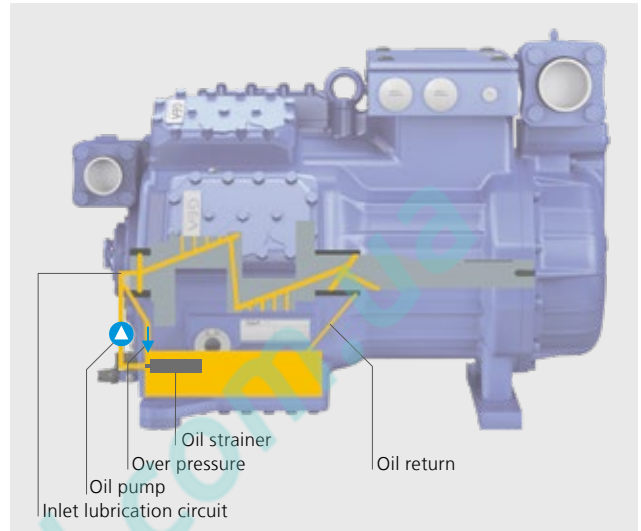

- All compressors with a conventional single circuit lubricating system
- All compressors with oil pump lubrication independent of direction of rotation
- Minimized oil carryover
- Service-friendly oil strainer
- Oil pump lubrication independent of direction of rotation
- Connection possibility for oil pressure monitoring
- Large-volume oil sump
- Coupling option for oil level regulator included as standard

---

**Service-friendly design**

---

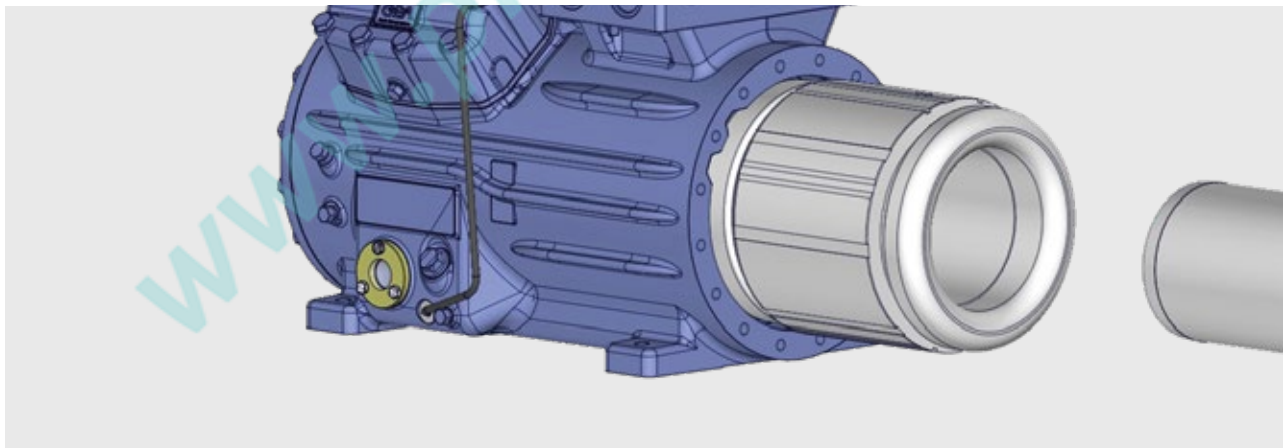

- Built-in motor easy to replace due to slide fit (not press fit)

---

### Oil sump heater

---

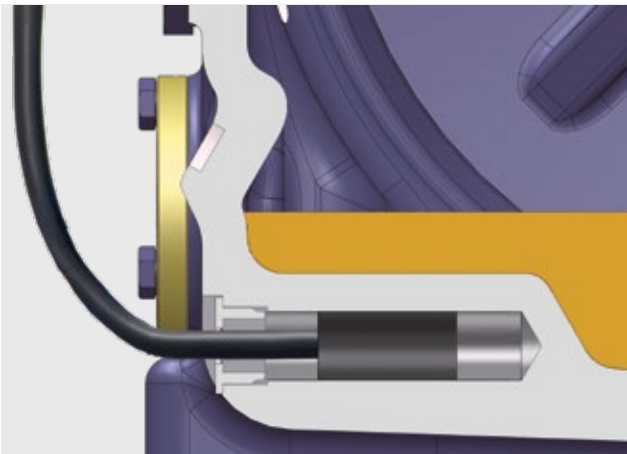

- PTC heater, self-regulating for HA22e und HA34e
- Constant power for HA44e

---

### Connection plug for oil monitoring with oil pressure safety switch MP55

---

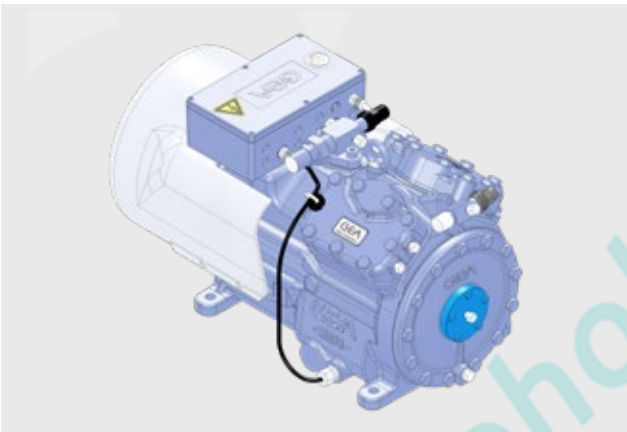

- HA22e to HA34e compressors

---

### Oil Temperature Sensor

---

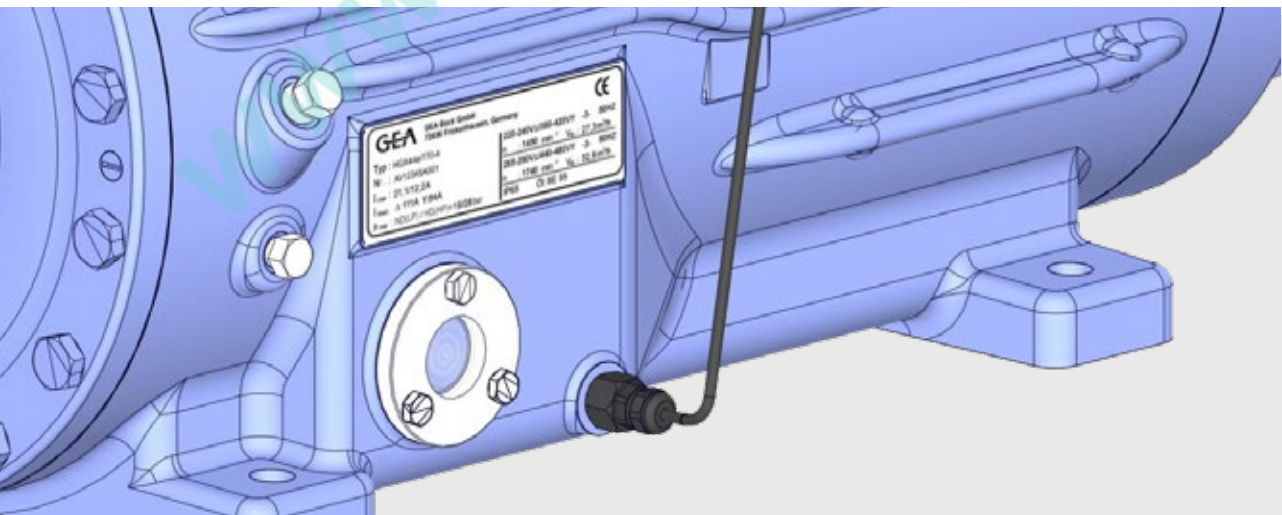

- Available for HA44e

**Wear-resistant durable driving gear**



- Solid design of eccentric shaft (HA22e - HA34e)
- Solid design of crankshaft (HA44e)
- High durability due to low friction sleeve bearings
- Low oil carryover due to aluminium pistons with double ring assembly
- Alluminium connecting rod with high-resistance piston bolt bearings (HA44e)
- Heavy-duty and robust split-forged connecting rod (HA44e)

**State-of-the-art terminal box**

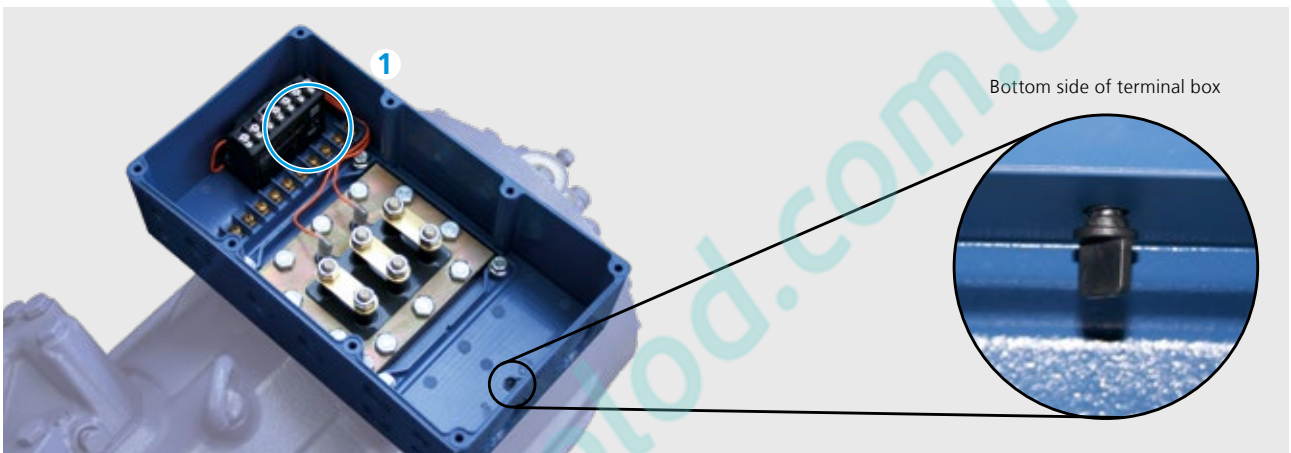

- Easy electrical installation due to large internal volume
- Terminal board with cable entry points in glass seal model
- **1** Electrical motor protection INT69 G integrated
- High level of protection IP44
- HA22e to HA44e equipped with plug to drain condensed water from the terminal box under unfavorable circumstances (when in use, IP class is reduced)

**Variable suction line valve position HA**

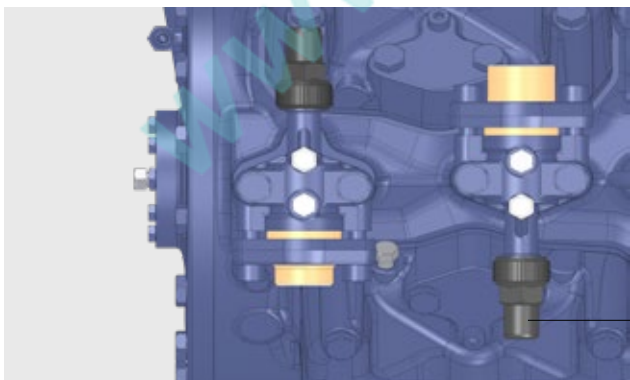

- HA22e, HA34e + HA44e
- Flexible position for suction line connection



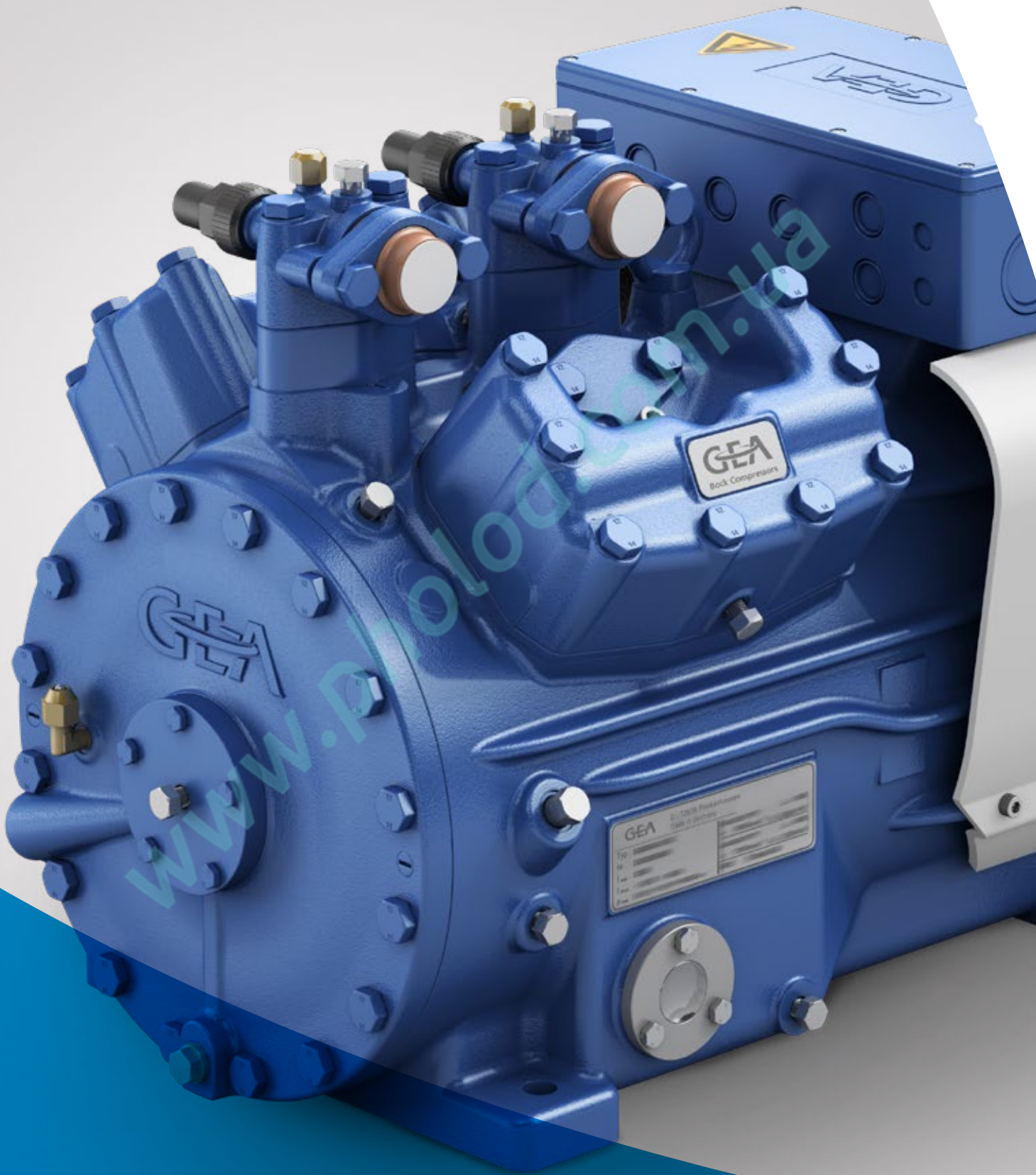



# GEA compressors HA semi-hermetic

GEA Bock HA22e – HA44e

[www.pholod.com.ua](http://www.pholod.com.ua)

## OPERATING LIMITS

### R404A/R507 Operating limits

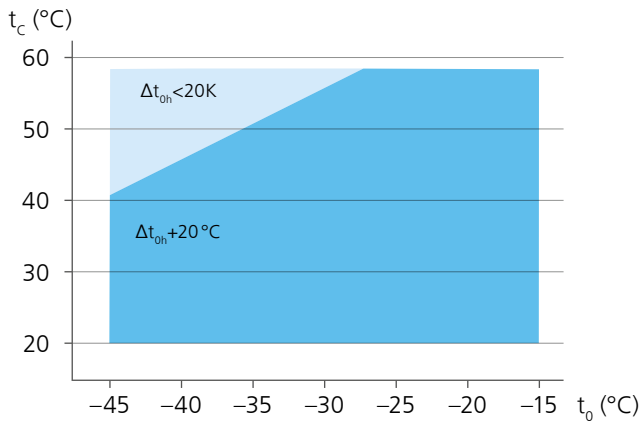

$t_o$  Evaporating temperature (°C)  
 $t_c$  Condensing temperature (°C)  
 $\Delta t_{oh}$  Suction gas superheat (K)  
 $t_{oh}$  Suction gas temperature (°C)

Max. permissible operating pressure (LP/HP)<sup>1)</sup>: 19/28 bar

- Unlimited application range
- Reduced suction gas temperature

<sup>1)</sup> LP = low pressure, HP = high pressure

## NOTES

### R404A/R507 Notes

#### Operating limits

Compressor operation is possible within the limits shown on the application diagrams. Please note the colored areas. Compressor application limits should not be chosen for design purposes or continuous operation.

Restrictions to operating limits may occur when using a Frequency converter.

For further explanations consult [www.gea.com](http://www.gea.com).

#### Performance data

The performance data for R404A/R507 are based on European Standard EN 12900 with a 50 Hz power supply frequency.

This signifies: 20°C suction gas temperature without liquid subcooling.

This leads to significant differences compared to systems with liquid subcooling and/or other suction gas temperatures.

Performance data were compiled for R404A and R507. The base values are the data for R404A.

Conversion factor for 60 Hz = 1.2

Performance data for other operating points, see GEA VAP software ([vap.gea.com](http://vap.gea.com)).

PERFORMANCE DATA

R404A/R507			50 Hz					
Type	Cond. temp. °C		Cooling capacity $\dot{Q}_0$ [W]				Power consumption $P_e$ [kW]	
			Evaporating temperature °C					
			-20	-25	-30	-35	-40	-45
HA22e/125-4	30	Q	4730	3800	2990	2300	1720	1250
		P	1,91	1,71	1,51	1,31	1,13	0,94
	40	Q	3960	3160	2470	1880	1390	978
		P	2,09	1,84	1,60	1,37	1,14	0,92
	50	Q	3220	2540	1960	1460	1040	690
		P	2,21	1,92	1,64	1,36	1,09	0,83
HA22e/160-4	30	Q	5840	4690	3690	2830	2120	1540
		P	2,36	2,11	1,86	1,62	1,39	1,16
	40	Q	4890	3900	3050	2320	1710	1210
		P	2,58	2,27	1,97	1,69	1,41	1,13
	50	Q	3970	3140	2420	1800	1290	851
		P	2,73	2,37	2,02	1,68	1,35	1,03
HA22e/190-4	30	Q	7070	5670	4460	3430	2570	1870
		P	2,86	2,55	2,25	1,96	1,68	1,41
	40	Q	5920	4720	3690	2810	2070	1460
		P	3,12	2,75	2,39	2,04	1,70	1,37
	50	Q	4800	3800	2930	2180	1550	1030
		P	3,31	2,87	2,45	2,04	1,64	1,24
HA34e/215-4	30	Q	8050	6450	5080	3900	2920	2130
		P	3,26	2,90	2,57	2,24	1,92	1,60
	40	Q	6740	5380	4200	3200	2350	1670
		P	3,55	3,13	2,72	2,33	1,94	1,56
	50	Q	5470	4320	3330	2480	1770	1180
		P	3,77	3,27	2,79	2,32	1,86	1,41
HA34e/255-4	30	Q	9460	7590	5970	4590	3440	2500
		P	3,83	3,42	3,02	2,63	2,26	1,88
	40	Q	7920	6320	4940	3760	2770	1960
		P	4,18	3,68	3,20	2,74	2,28	1,84
	50	Q	6430	5080	3920	2920	2080	1380
		P	4,43	3,84	3,28	2,73	2,19	1,66
HA34e/315-4	30	Q	11700	9370	7370	5660	4240	3080
		P	4,73	4,22	3,73	3,25	2,79	2,33
	40	Q	9780	7800	6090	4640	3420	2420
		P	5,16	4,54	3,95	3,38	2,82	2,27
	50	Q	7930	6270	4830	3600	2570	1710
		P	5,47	4,75	4,05	3,37	2,71	2,06
HA34e/380-4	30	Q	14200	11400	8910	6850	5130	3730
		P	5,50	4,96	4,39	3,81	3,22	2,65
	40	Q	11900	9440	7370	5610	4130	2920
		P	5,95	5,28	4,58	3,86	3,16	2,74
	50	Q	9600	7590	5850	4360	3100	2060
		P	6,25	5,43	4,59	3,74	3,28	2,07
HA44e/475-4	30	Q	18700	15100	11900	9100	6800	4890
		P	6,64	6,01	5,35	4,66	3,95	3,24
	40	Q	15700	12600	9760	7430	5450	3810
		P	7,13	6,32	5,47	4,62	3,76	2,91
	50	Q	12900	10200	7830	5880	4230	2850
		P	7,44	6,43	5,41	4,39	3,38	2,40
HA44e/565-4	30	Q	21900	17600	13900	10800	8040	5800
		P	8,08	7,36	6,58	5,77	4,93	4,09
	40	Q	18400	14700	11500	8770	6470	4530
		P	8,73	7,79	6,82	5,83	4,83	3,84
	50	Q	15100	11900	9230	6950	5020	3400
		P	9,17	8,02	6,85	5,68	4,52	3,39
HA44e/665-4	30	Q	25000	20200	16000	12400	9310	6750
		P	9,33	8,43	7,49	6,52	5,53	4,55
	40	Q	21100	16900	13300	10200	7480	5270
		P	10,10	8,97	7,79	6,60	5,42	4,27
	50	Q	17200	13700	10600	8010	5810	3960
		P	10,70	9,29	7,87	6,47	5,10	3,78

Relating to 20°C suction gas temperature without liquid subcooling

■ Reduced suction gas temperature

## OPERATING LIMITS

## R448A Operating limits

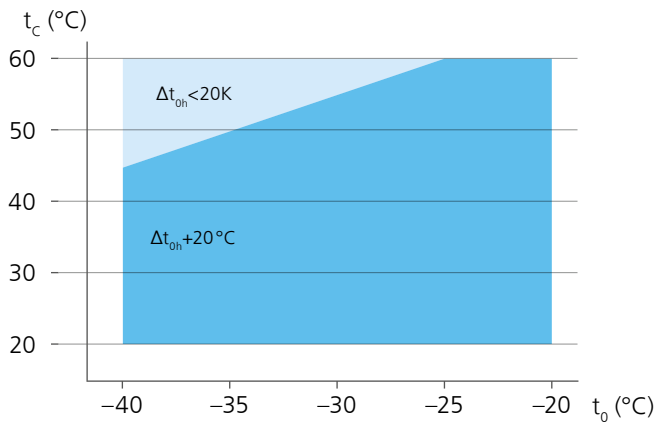

$t_o$  Evaporating temperature (°C)  
 $t_c$  Condensing temperature (°C)  
 $\Delta t_{oh}$  Suction gas superheat (K)  
 $t_{oh}$  Suction gas temperature (°C)

Max. permissible operating pressure (LP/HP)<sup>1)</sup>: 19/28 bar

- Unlimited application range
- Reduced suction gas temperature

<sup>1)</sup> LP = low pressure, HP = high pressure

## NOTES

## R448A Notes

**Operating limits**

Compressor operation is possible within the limits shown on the application diagrams. Please note the colored areas. Compressor application limits should not be chosen for design purposes or continuous operation.

Restrictions to operating limits may occur when using a Frequency converter.

For further explanations consult [www.gea.com](http://www.gea.com).

**Performance data**

The performance data for R448A are based on European Standard EN 12900 with a 50 Hz power supply frequency.

This signifies: 20°C suction gas temperature without liquid subcooling.

Evaporation and condensing temperatures are based on the dew point values (saturated vapour conditions).

Conversion factor for 60 Hz = 1.2

Performance data for other operating points, see GEA VAP software ([vap.gea.com](http://vap.gea.com)).

## PERFORMANCE DATA

R448A			50 Hz				
Type	Cond. temp. °C		Cooling capacity $\dot{Q}_0$ [W]			Power consumption $P_e$ [kW]	
			Evaporating temperature °C				
			-20	-25	-30	-35	-40
HA22e/125-4	30	Q	4190	3250	2450	1780	1230
		P	1,70	1,53	1,36	1,18	1,00
	40	Q	3530	2700	2000	1410	915
		P	1,81	1,59	1,38	1,16	0,96
	50	Q	2910	2190	1570	1060	631
		P	1,87	1,62	1,36	1,12	0,88
HA22e/160-4	30	Q	5220	4030	3020	2170	1470
		P	2,03	1,83	1,62	1,39	1,17
	40	Q	4420	3350	2450	1700	1070
		P	2,17	1,90	1,64	1,37	1,10
	50	Q	3640	2700	1910	1250	691
		P	2,25	1,93	1,61	1,30	1,00
HA22e/190-4	30	Q	6310	4940	3780	2810	2010
		P	2,48	2,23	1,97	1,71	1,45
	40	Q	5440	4210	3170	2300	1570
		P	2,67	2,35	2,03	1,71	1,40
	50	Q	4570	3470	2550	1780	1140
		P	2,80	2,41	2,03	1,66	1,30
HA34e/215-4	30	Q	6790	5230	3920	2810	1900
		P	2,59	2,32	2,03	1,74	1,44
	40	Q	5690	4300	3120	2130	1310
		P	2,78	2,41	2,04	1,67	1,31
	50	Q	4600	3370	2330	1460	731
		P	2,87	2,41	1,96	1,52	1,10
HA34e/255-4	30	Q	8250	6410	4850	3540	2460
		P	3,16	2,81	2,45	2,08	1,72
	40	Q	6980	5340	3960	2800	1840
		P	3,39	2,94	2,49	2,05	1,62
	50	Q	5740	4310	3100	2090	1240
		P	3,54	2,99	2,46	1,94	1,45
HA34e/315-4	30	Q	10400	8020	6020	4370	3010
		P	3,86	3,44	3,00	2,55	2,12
	40	Q	8790	6670	4890	3410	2220
		P	4,16	3,60	3,05	2,51	1,99
	50	Q	7190	5320	3770	2490	1460
		P	4,34	3,66	3,00	2,36	1,77
HA34e/380-4	30	Q	12700	9820	7430	5430	3780
		P	4,76	4,23	3,69	3,14	2,60
	40	Q	10800	8220	6070	4260	2770
		P	5,17	4,50	3,82	3,15	2,50
	50	Q	8860	6600	4690	3090	1760
		P	5,44	4,62	3,80	3,01	2,26
HA44e/475-4	30	Q	16300	12600	9480	6890	4750
		P	5,79	5,18	4,54	3,87	3,21
	40	Q	13900	10600	7750	5420	3490
		P	6,21	5,41	4,60	3,78	2,98
	50	Q	11500	8500	6040	3970	2250
		P	6,47	5,48	4,49	3,52	2,58
HA44e/565-4	30	Q	20200	15700	11900	8740	6130
		P	7,06	6,33	5,57	4,78	3,99
	40	Q	17400	13400	9920	7070	4710
		P	7,63	6,70	5,74	4,78	3,84
	50	Q	14600	11000	7950	5420	3310
		P	8,02	6,88	5,74	4,61	3,53
HA44e/665-4	30	Q	22800	17800	13600	9960	7030
		P	8,06	7,19	6,27	5,34	4,42
	40	Q	19700	15100	11300	8100	5450
		P	8,76	7,63	6,49	5,36	4,26
	50	Q	16500	12500	9090	6270	3910
		P	9,27	7,88	6,52	5,19	3,93

Relating to 20°C suction gas temperature without liquid subcooling

 Reduced suction gas temperature

## OPERATING LIMITS

## R449A Operating limits

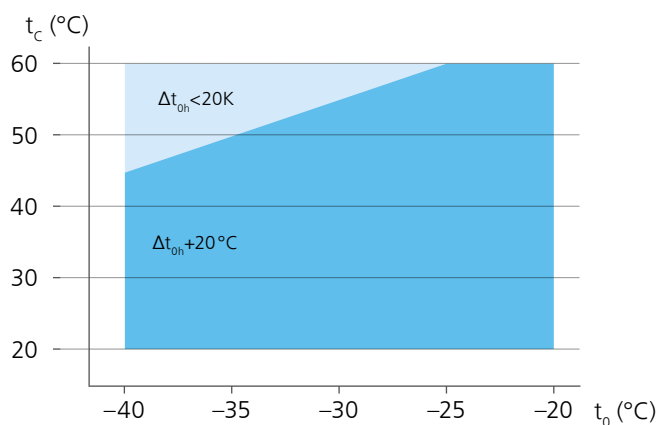

$t_o$  Evaporating temperature (°C)

$t_c$  Condensing temperature (°C)

$\Delta t_{oh}$  Suction gas superheat (K)

$t_{oh}$  Suction gas temperature (°C)

Max. permissible operating pressure (LP/HP)<sup>1)</sup>: 19/28 bar

● Unlimited application range

○ Reduced suction gas temperature

<sup>1)</sup> LP = low pressure, HP = high pressure

## NOTES

## R449A Notes

**Operating limits**

Compressor operation is possible within the limits shown on the application diagrams. Please note the colored areas. Compressor application limits should not be chosen for design purposes or continuous operation.

Restrictions to operating limits may occur when using a Frequency converter.

For further explanations consult [www.gea.com](http://www.gea.com).

**Performance data**

The performance data for R449A are based on European Standard EN 12900 with a 50 Hz power supply frequency.

This signifies: 20°C suction gas temperature without liquid subcooling.

Evaporation and condensing temperatures are based on the dew point values (saturated vapour conditions).

Conversion factor for 60 Hz = 1.2

Performance data for other operating points, see GEA VAP software ([vap.gea.com](http://vap.gea.com)).



## PERFORMANCE DATA

R449A			50 Hz				
Type	Cond. temp. °C		Cooling capacity $\dot{Q}_0$ [W]			Power consumption $P_e$ [kW]	
			Evaporating temperature °C				
			-20	-25	-30	-35	-40
HA22e/125-4	30	Q	4170	3240	2440	1780	1230
		P	1,69	1,53	1,35	1,18	1,00
	40	Q	3520	2690	1990	1400	912
		P	1,80	1,59	1,37	1,16	0,96
	50	Q	2890	2170	1570	1060	628
		P	1,87	1,61	1,36	1,11	0,88
HA22e/160-4	30	Q	5200	4010	3010	2160	1470
		P	2,03	1,83	1,61	1,39	1,17
	40	Q	4400	3340	2440	1690	1070
		P	2,16	1,90	1,63	1,36	1,10
	50	Q	3620	2680	1900	1240	688
		P	2,24	1,92	1,60	1,29	1,00
HA22e/190-4	30	Q	6280	4920	3770	2800	2010
		P	2,47	2,22	1,96	1,70	1,44
	40	Q	5420	4190	3150	2290	1570
		P	2,66	2,34	2,02	1,70	1,40
	50	Q	4540	3450	2540	1770	1130
		P	2,79	2,40	2,02	1,65	1,30
HA34e/215-4	30	Q	6760	5220	3900	2810	1900
		P	2,59	2,31	2,03	1,74	1,44
	40	Q	5670	4280	3110	2130	1310
		P	2,76	2,40	2,03	1,67	1,31
	50	Q	4580	3350	2320	1450	728
		P	2,86	2,40	1,96	1,52	1,10
HA34e/255-4	30	Q	8220	6390	4830	3530	2460
		P	3,15	2,80	2,44	2,08	1,72
	40	Q	6940	5320	3940	2790	1830
		P	3,37	2,93	2,48	2,04	1,62
	50	Q	5700	4280	3080	2080	1240
		P	3,52	2,98	2,45	1,94	1,45
HA34e/315-4	30	Q	10400	7990	6010	4360	3010
		P	3,85	3,42	2,99	2,55	2,11
	40	Q	8740	6640	4870	3400	2210
		P	4,14	3,59	3,04	2,50	1,99
	50	Q	7150	5290	3750	2480	1450
		P	4,32	3,65	2,99	2,36	1,77
HA34e/380-4	30	Q	12600	9790	7410	5420	3770
		P	4,74	4,22	3,68	3,14	2,60
	40	Q	10800	8180	6040	4250	2760
		P	5,15	4,48	3,81	3,14	2,49
	50	Q	8800	6560	4660	3070	1750
		P	5,42	4,60	3,79	3,00	2,25
HA44e/475-4	30	Q	16200	12600	9450	6870	4740
		P	5,77	5,16	4,52	3,86	3,20
	40	Q	13800	10500	7720	5400	3480
		P	6,19	5,39	4,58	3,77	2,97
	50	Q	11400	8450	6000	3950	2240
		P	6,44	5,46	4,47	3,51	2,58
HA44e/565-4	30	Q	20100	15700	11900	8720	6120
		P	7,03	6,31	5,55	4,77	3,98
	40	Q	17300	13300	9880	7050	4690
		P	7,60	6,67	5,72	4,77	3,83
	50	Q	14500	11000	7910	5390	3290
		P	7,99	6,85	5,72	4,60	3,52
HA44e/665-4	30	Q	22700	17700	13500	9940	7020
		P	8,04	7,16	6,26	5,33	4,41
	40	Q	19600	15100	11300	8070	5430
		P	8,73	7,60	6,47	5,34	4,25
	50	Q	16400	12400	9040	6240	3890
		P	9,23	7,85	6,49	5,18	3,92

Relating to 20°C suction gas temperature without liquid subcooling

■ Reduced suction gas temperature

## OPERATING LIMITS

### R407A Operating limits

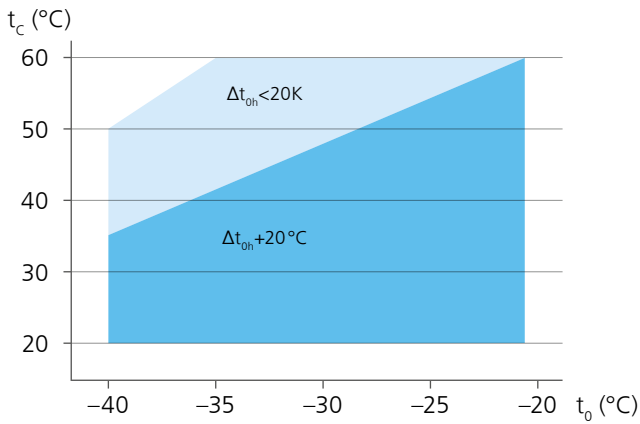

$t_o$  Evaporating temperature (°C)  
 $t_c$  Condensing temperature (°C)  
 $\Delta t_{oh}$  Suction gas superheat (K)  
 $t_{oh}$  Suction gas temperature (°C)

Max. permissible operating pressure (LP/HP)<sup>1)</sup>: 19/28 bar

- Unlimited application range
- Reduced suction gas temperature

<sup>1)</sup> LP = low pressure, HP = high pressure

## NOTES

### R407A Notes

#### Operating limits

Compressor operation is possible within the limits shown on the application diagrams. Please note the colored areas. Compressor application limits should not be chosen for design purposes or continuous operation.

Restrictions to operating limits may occur when using a Frequency converter.

For further explanations consult [www.gea.com](http://www.gea.com).

#### Performance data

The performance data for R407A are based on European Standard EN 12900 with a 50 Hz power supply frequency.

This signifies: 20°C suction gas temperature without liquid subcooling.

Evaporation and condensing temperatures are based on the dew point values (saturated vapour conditions).

Conversion factor for 60 Hz = 1.2

Performance data for other operating points, see GEA VAP software ([vap.gea.com](http://vap.gea.com)).

## PERFORMANCE DATA

R407A			50 Hz				
Type	Cond. temp. °C		Cooling capacity $\dot{Q}_0$ [W]			Power consumption $P_e$ [kW]	
			Evaporating temperature °C				
			-20	-25	-30	-35	-40
HA22e/125-4	30	Q	4090	3120	2330	1680	1140
		P	1,65	1,48	1,30	1,12	0,95
	40	Q	3460	2600	1900	1310	804
		P	1,76	1,53	1,30	1,08	0,88
	50	Q	2830	2070	1450	923	454
		P	1,81	1,53	1,26	1,00	0,77
HA22e/160-4	30	Q	5110	3890	2870	2030	1350
		P	1,98	1,77	1,54	1,32	1,10
	40	Q	4330	3230	2310	1550	920
		P	2,10	1,82	1,54	1,27	1,00
	50	Q	3530	2550	1730	1060	503
		P	2,16	1,82	1,48	1,15	0,84
HA22e/190-4	30	Q	6160	4750	3610	2670	1880
		P	2,41	2,15	1,88	1,62	1,36
	40	Q	5330	4060	3020	2150	1400
		P	2,59	2,25	1,92	1,59	1,29
	50	Q	4440	3310	2370	1560	844
		P	2,70	2,28	1,87	1,48	1,12
HA34e/215-4	30	Q	6700	5120	3790	2680	1770
		P	2,51	2,25	1,97	1,68	1,39
	40	Q	5630	4200	3000	2000	1170
		P	2,69	2,33	1,97	1,60	1,24
	50	Q	4540	3260	2200	1310	561
		P	2,78	2,32	1,87	1,42	1,00
HA34e/255-4	30	Q	8160	6290	4710	3390	2310
		P	3,05	2,71	2,37	2,01	1,66
	40	Q	6920	5240	3820	2640	1660
		P	3,28	2,85	2,40	1,96	1,54
	50	Q	5680	4190	2940	1900	1030
		P	3,43	2,89	2,35	1,83	1,33
HA34e/315-4	30	Q	10300	7850	5850	4180	2810
		P	3,76	3,33	2,88	2,42	1,97
	40	Q	8630	6500	4710	3220	1990
		P	4,04	3,48	2,91	2,35	1,80
	50	Q	7060	5180	3600	2280	1200
		P	4,21	3,51	2,83	2,16	1,52
HA34e/380-4	30	Q	12500	9590	7220	5230	3540
		P	4,64	4,10	3,55	2,98	2,42
	40	Q	10600	8010	5870	4060	2480
		P	5,03	4,35	3,65	2,95	2,26
	50	Q	8690	6420	4500	2860	1390
		P	5,28	4,44	3,60	2,76	1,95
HA44e/475-4	30	Q	15800	12200	9080	6510	4400
		P	5,69	5,08	4,44	3,78	3,11
	40	Q	13400	10100	7350	5050	3160
		P	6,08	5,28	4,46	3,64	2,84
	50	Q	11000	8090	5650	3620	1940
		P	6,30	5,31	4,32	3,35	2,41
HA44e/565-4	30	Q	19600	15200	11400	8280	5710
		P	6,94	6,22	5,45	4,66	3,88
	40	Q	16800	12800	9430	6630	4310
		P	7,48	6,54	5,58	4,63	3,69
	50	Q	14100	10500	7490	5000	2940
		P	7,83	6,69	5,54	4,42	3,34
HA44e/665-4	30	Q	22200	17200	13000	9450	6560
		P	7,93	7,05	6,14	5,21	4,29
	40	Q	19000	14600	10800	7600	5000
		P	8,58	7,44	6,30	5,18	4,09
	50	Q	15900	11900	8570	5800	3490
		P	9,03	7,65	6,29	4,97	3,72

Relating to 20°C suction gas temperature without liquid subcooling

 Reduced suction gas temperature

## OPERATING LIMITS

## R407F Operating limits

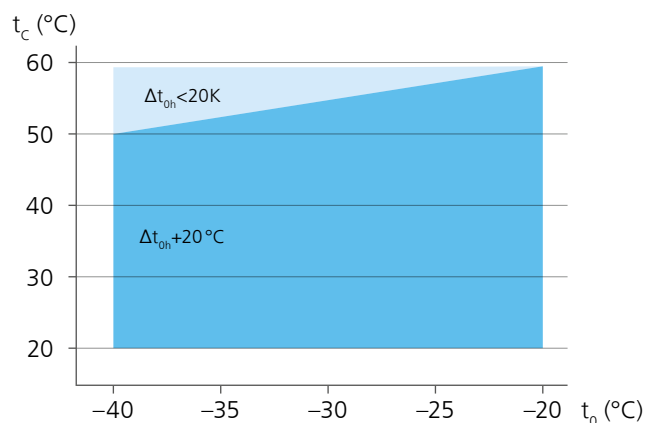

$t_o$  Evaporating temperature (°C)

$t_c$  Condensing temperature (°C)

$\Delta t_{oh}$  Suction gas superheat (K)

$t_{oh}$  Suction gas temperature (°C)

Max. permissible operating pressure (LP/HP)<sup>1)</sup>: 19/28 bar

● Unlimited application range

○ Reduced suction gas temperature

<sup>1)</sup> LP = low pressure, HP = high pressure

## NOTES

## R407F Notes

**Operating limits**

Compressor operation is possible within the limits shown on the application diagrams. Please note the colored areas. Compressor application limits should not be chosen for design purposes or continuous operation.

Restrictions to operating limits may occur when using a Frequency converter.

For further explanations consult [www.gea.com](http://www.gea.com).

**Performance data**

The performance data for R407F are based on European Standard EN 12900 with a 50 Hz power supply frequency.

This signifies: 20°C suction gas temperature without liquid subcooling.

Evaporation and condensing temperatures are based on the dew point values (saturated vapour conditions).

Conversion factor for 60 Hz = 1.2

Performance data for other operating points, see GEA VAP software ([vap.gea.com](http://vap.gea.com)).

## PERFORMANCE DATA

		R407F		50 Hz				
Type	Cond. temp. °C	Cooling capacity $\dot{Q}_0$ [W]			Power consumption $P_e$ [kW]			
		Evaporating temperature °C						
		-20	-25	-30	-35	-40		
HA22e/125-4	30	Q	4300	3270	2420	1730	1190	
		P	1,72	1,54	1,35	1,17	1,00	
	40	Q	3670	2740	1990	1380	912	
		P	1,84	1,60	1,37	1,15	0,96	
	50	Q	3030	2220	1570	1060	669	
		P	1,90	1,62	1,35	1,11	0,90	
HA22e/160-4	30	Q	5370	4060	2980	2110	1420	
		P	2,06	1,84	1,61	1,38	1,17	
	40	Q	4590	3400	2440	1660	1060	
		P	2,20	1,91	1,62	1,36	1,11	
	50	Q	3790	2750	1900	1230	722	
		P	2,28	1,93	1,59	1,29	1,02	
HA22e/190-4	30	Q	6490	4990	3750	2740	1960	
		P	2,52	2,24	1,96	1,70	1,45	
	40	Q	5660	4280	3160	2260	1580	
		P	2,72	2,36	2,02	1,70	1,41	
	50	Q	4770	3540	2550	1780	1210	
		P	2,84	2,41	2,01	1,65	1,33	
HA34e/215-4	30	Q	7030	5370	3970	2820	1910	
		P	2,67	2,37	2,06	1,75	1,45	
	40	Q	5930	4440	3180	2150	1330	
		P	2,86	2,47	2,07	1,68	1,32	
	50	Q	4800	3480	2360	1450	726	
		P	2,94	2,45	1,97	1,51	1,09	
HA34e/255-4	30	Q	8540	6570	4920	3560	2480	
		P	3,25	2,87	2,48	2,09	1,73	
	40	Q	7270	5510	4040	2840	1880	
		P	3,49	3,00	2,52	2,06	1,64	
	50	Q	6000	4450	3170	2120	1290	
		P	3,63	3,05	2,48	1,94	1,46	
HA34e/315-4	30	Q	10800	8160	6000	4240	2860	
		P	4,03	3,53	3,03	2,54	2,09	
	40	Q	9110	6770	4860	3320	2120	
		P	4,33	3,69	3,07	2,49	1,97	
	50	Q	7460	5410	3760	2450	1450	
		P	4,50	3,73	3,01	2,35	1,78	
HA34e/380-4	30	Q	13100	9990	7400	5280	3580	
		P	4,97	4,36	3,74	3,14	2,57	
	40	Q	11200	8350	6030	4140	2630	
		P	5,38	4,61	3,85	3,13	2,47	
	50	Q	9190	6700	4650	3010	1720	
		P	5,64	4,71	3,82	3,00	2,25	
HA44e/475-4	30	Q	17000	13000	9640	6910	4670	
		P	5,99	5,34	4,65	3,95	3,25	
	40	Q	14500	11000	7980	5560	3570	
		P	6,42	5,59	4,75	3,93	3,13	
	50	Q	11900	8800	6260	4170	2460	
		P	6,68	5,67	4,69	3,75	2,87	
HA44e/565-4	30	Q	21100	16200	12100	8770	6050	
		P	7,30	6,52	5,72	4,89	4,05	
	40	Q	18200	13900	10300	7270	4850	
		P	7,88	6,91	5,94	4,99	4,06	
	50	Q	15200	11400	8270	5730	3640	
		P	8,28	7,13	6,01	4,94	3,94	
HA44e/665-4	30	Q	23900	18300	13800	10100	6950	
		P	8,35	7,42	6,45	5,47	4,49	
	40	Q	20600	15700	11700	8350	5620	
		P	9,07	7,90	6,73	5,60	4,53	
	50	Q	17200	13000	9480	6650	4310	
		P	9,59	8,19	6,86	5,60	4,45	

Relating to 20°C suction gas temperature without liquid subcooling

■ Reduced suction gas temperature

## OPERATING LIMITS

### R22 Operating limits

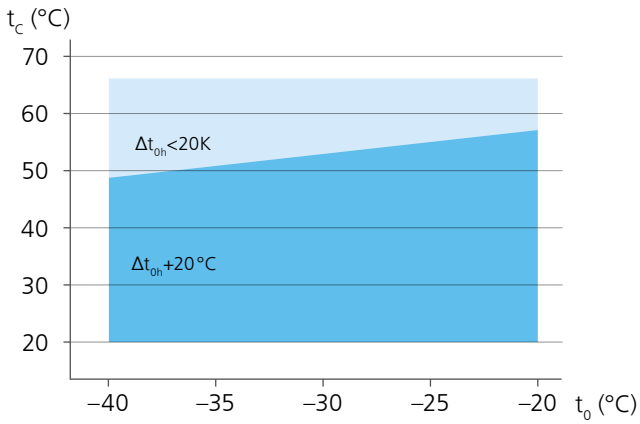

$t_o$  Evaporating temperature (°C)  
 $t_c$  Condensing temperature (°C)  
 $\Delta t_{oh}$  Suction gas superheat (K)  
 $t_{oh}$  Suction gas temperature (°C)

Max. permissible operating pressure (LP/HP)<sup>1)</sup>: 19/28 bar

- Unlimited application range
- Reduced suction gas temperature

<sup>1)</sup> LP = low pressure, HP = high pressure

## NOTES

### R22 Notes

#### Operating limits

Compressor operation is possible within the limits shown on the application diagrams. Please note the colored areas. Compressor application limits should not be chosen for design purposes or continuous operation.

Restrictions to operating limits may occur when using a Frequency converter.  
 For further explanations consult [www.gea.com](http://www.gea.com).

#### Performance data

The performance data for R22 are based on European Standard EN 12900 with a 50 Hz power supply frequency. This signifies: 20 °C suction gas temperature without liquid subcooling.

This results in significant differences compared to specifications with liquid undercooling and/or suction-gas temperatures. A comprehensive modification to 20 °C suction gas temperature will follow at a later date.

Conversion factor for 60 Hz = 1.2

Performance data for other operating points, see GEA VAP software ([vap.gea.com](http://vap.gea.com)).



## PERFORMANCE DATA

		R22		50 Hz				
Type	Cond. temp. °C	Cooling capacity $\dot{Q}_0$ [W]			Power consumption $P_e$ [kW]			
		Evaporating temperature °C						
		-20	-25	-30	-35	-40		
HA22e/125-4	30	Q	4270	3360	2590	1930	1390	
		P	1,73	1,58	1,42	1,26	1,09	
	40	Q	3710	2890	2190	1600	1100	
		P	1,86	1,67	1,47	1,27	1,07	
	50	Q	3180	2440	1820	1290	836	
		P	1,96	1,73	1,49	1,25	1,03	
HA22e/160-4	30	Q	5330	4180	3200	2370	1680	
		P	2,07	1,89	1,70	1,50	1,29	
	40	Q	4650	3600	2700	1950	1310	
		P	2,23	2,00	1,75	1,50	1,26	
	50	Q	3980	3040	2230	1540	960	
		P	2,35	2,06	1,77	1,48	1,19	
HA22e/190-4	30	Q	6400	5080	3960	3010	2230	
		P	2,52	2,29	2,06	1,82	1,57	
	40	Q	5670	4460	3430	2560	1840	
		P	2,74	2,45	2,15	1,86	1,57	
	50	Q	4950	3840	2910	2120	1450	
		P	2,92	2,56	2,21	1,86	1,52	
HA34e/215-4	30	Q	6950	5450	4180	3100	2200	
		P	2,65	2,41	2,15	1,89	1,62	
	40	Q	6030	4660	3490	2500	1670	
		P	2,87	2,55	2,22	1,88	1,54	
	50	Q	5110	3870	2800	1900	1140	
		P	3,04	2,63	2,21	1,80	1,41	
HA34e/255-4	30	Q	8420	6640	5130	3850	2780	
		P	3,22	2,90	2,58	2,24	1,91	
	40	Q	7340	5720	4350	3190	2220	
		P	3,49	3,09	2,68	2,27	1,86	
	50	Q	6290	4840	3600	2560	1680	
		P	3,71	3,21	2,72	2,23	1,77	
HA34e/315-4	30	Q	10600	8310	6380	4750	3410	
		P	3,92	3,55	3,15	2,75	2,35	
	40	Q	9240	7150	5390	3910	2690	
		P	4,29	3,79	3,28	2,78	2,29	
	50	Q	7890	6010	4420	3090	1990	
		P	4,56	3,94	3,32	2,73	2,16	
HA34e/380-4	30	Q	12900	10200	7830	5880	4250	
		P	4,82	4,35	3,86	3,36	2,85	
	40	Q	11300	8780	6650	4850	3350	
		P	5,31	4,70	4,08	3,45	2,84	
	50	Q	9670	7400	5460	3820	2430	
		P	5,68	4,92	4,17	3,43	2,71	
HA44e/475-4	30	Q	16600	13100	10100	7510	5390	
		P	5,88	5,35	4,77	4,17	3,56	
	40	Q	14600	11300	8550	6220	4270	
		P	6,40	5,69	4,95	4,19	3,44	
	50	Q	12600	9580	7070	4940	3150	
		P	6,79	5,89	4,98	4,08	3,19	
HA44e/565-4	30	Q	20500	16200	12500	9420	6850	
		P	7,15	6,51	5,82	5,10	4,37	
	40	Q	18100	14200	10900	7970	5590	
		P	7,83	6,98	6,11	5,23	4,34	
	50	Q	15800	12200	9120	6520	4330	
		P	8,35	7,31	6,26	5,21	4,18	
HA44e/665-4	30	Q	23200	18400	14300	10800	7850	
		P	8,17	7,39	6,57	5,72	4,86	
	40	Q	20500	16100	12300	9120	6450	
		P	8,99	7,97	6,92	5,87	4,84	
	50	Q	17900	13900	10500	7520	5070	
		P	9,65	8,38	7,12	5,88	4,68	

Relating to 20°C suction gas temperature without liquid subcooling

■ Reduced suction gas temperature

## TECHNICAL DATA

## HA

Type	Number of cylinders	Displacement 50 / 60 Hz (1,450/1,740 rpm)  m <sup>3</sup> /h	Electrical data				Weight  kg	Connections <sup>5)</sup>		Oil charge  Ltr.
			Voltage <sup>1)</sup>	Max. working current <sup>2)</sup>  A (Δ / Y)	Max. power consumption <sup>2)</sup>  kW	Starting current (rotor locked)  A (Δ / Y)		Discharge line DV  mm   inch	Suction line SV  mm   inch	
<b>HA22e/125-4</b>	2	11.10 / 13.30	3	8.1 / 4.7	2.4	69 / 40	75.5	12   1/2	16   5/8	0.9
<b>HA22e/160-4</b>	2	13.70 / 16.40	3	9.6 / 5.5	2.9	87 / 50	77.5	12   1/2	16   5/8	0.9
<b>HA22e/190-4</b>	2	16.50 / 19.80	3	10.9 / 6.3	3.5	87 / 50	76.5	12   1/2	16   5/8	0.9
<b>HA34e/215-4</b>	4	18.80 / 22.60	3	12.1 / 7.0	4.0	87 / 50	94.0	16   5/8	22   7/8	1.2
<b>HA34e/255-4</b>	4	22.10 / 26.60	3	13.8 / 8.0	4.7	87 / 50	93.5	16   5/8	22   7/8	1.2
<b>HA34e/315-4</b>	4	27.30 / 32.80	3	17.1 / 9.9	5.8	111 / 64	96.5	16   5/8	22   7/8	1.2
<b>HA34e/380-4</b>	4	33.10 / 39.70	3	19.4 / 11.2	6.4	132 / 76	96.0	16   5/8	22   7/8	1.2
				PW 1+2*		PW1 / PW 1+2*				
<b>HA44e/475-4</b>	4	40.50 / 48.60	4	15.2	7.6	87 / 149	174.0	28   1 1/8	35   1 3/8	2.3
<b>HA44e/565-4</b>	4	48.20 / 57.80	4	18.3	9.4	101 / 174	178.5	28   1 1/8	35   1 3/8	2.3
<b>HA44e/665-4</b>	4	56.60 / 67.90	4	20.3	11.0	101 / 174	173.5	28   1 1/8	35   1 3/8	2.3

\* PW = Part Winding, motors for part winding star 1 = 1st part winding 2 = 2nd part winding

## Explanations:

- 1) Tolerance ( $\pm 10\%$ ) relates to the mean value of the voltage range. Other voltages and current types on request.
- 2) • The specifications for max. power consumption apply for 50 Hz operation. For 60 Hz operation, the specifications have to be multiplied by the factor 1.2. The max. working current remains unchanged.  
• Take account of the max. operating current / max. power consumption when designing contactors, leads and fuses. Switches: Service category AC3
- 3) 220-240 V Δ / 380-420 V Y - 3 - 50 Hz,  
265-290 V Δ / 440-480 V Y - 3 - 60 Hz
- 4) PW = Part Winding, motors for part winding start (no start unloaders required)
  - Winding ratios: HA44e 50% / 50%
  - Designs for Y/Δ on request
- 5) For soldering connections

## Oil sump heater 110-240 V - 1 - 50/60 Hz (option)

- HA22e, HA34e: 50–120 W
- PTC heater, self-regulating, installation in housing bore

## Oil sump heater 230 V - 1 - 50/60 Hz (option)

- HA44e: 160 W
- Permanently set version, installation in immersion sleeve

## Fan motors for the HA version 230 V - 1 - 50/60 Hz

- HA22e, HA34e: 38 W / 0.17 A
- HA44e: 140W / 0.71 A

DIMENSIONS AND CONNECTIONS

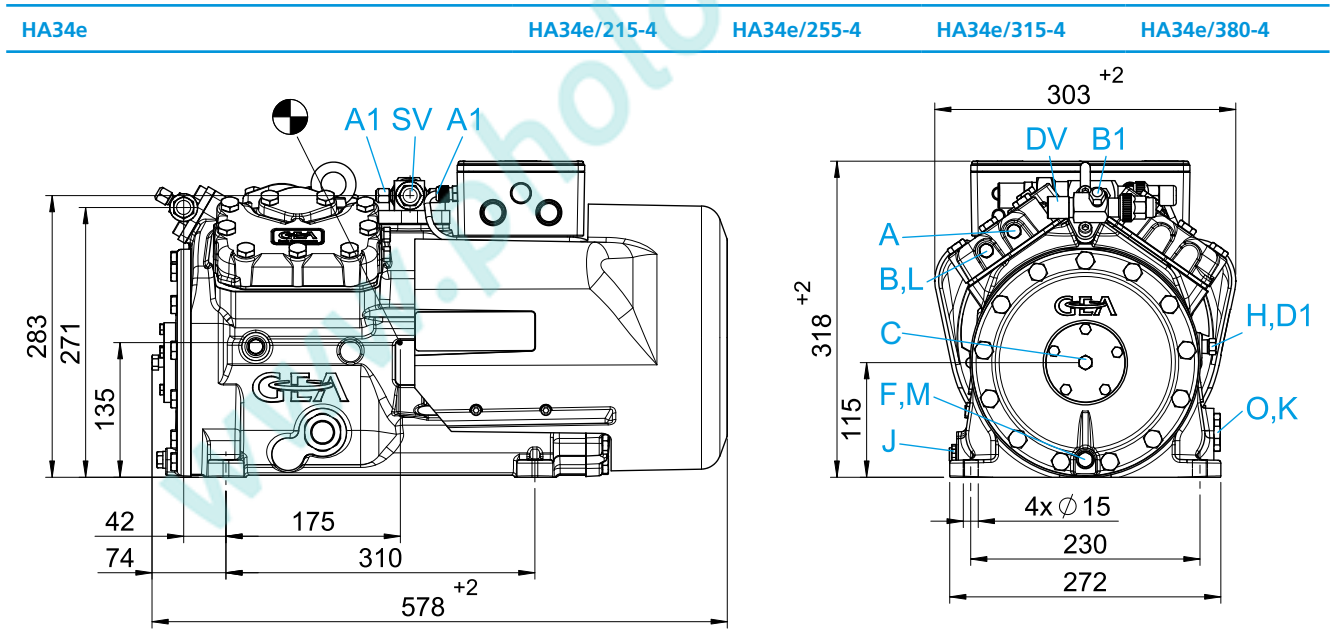
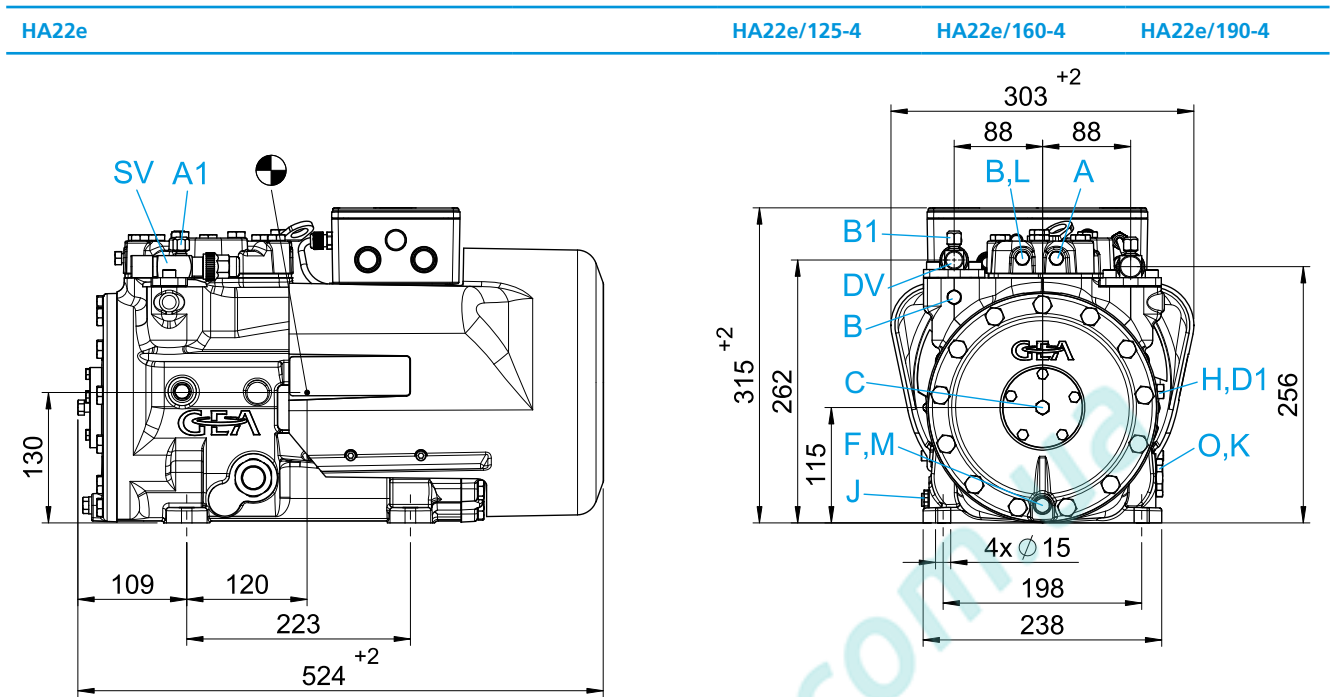

Dimensions in mm  
 ● Center of gravity

Connections see page 33  
 Dimensions for anti-vibration pad see page 31  
 Dimensions for view X see page 31

DIMENSIONS AND CONNECTIONS

HA44e

HA44e/475-4

HA44e/565-4

HA44e/665-4

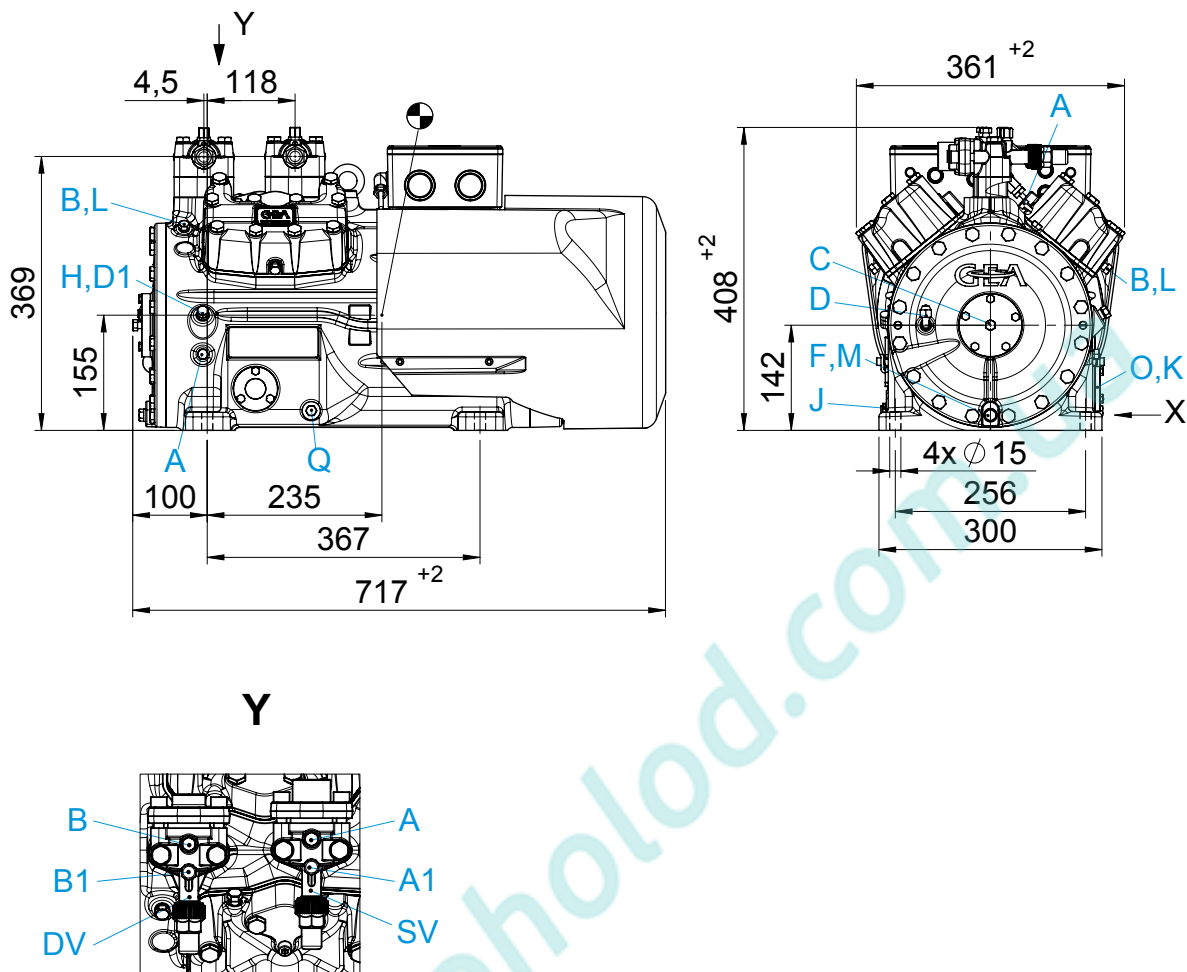

Dimensions in mm  
 ⊕ Center of gravity

Connections see page 33  
 Dimensions for anti-vibration pad see page 31  
 Dimensions for view X see page 31

View X

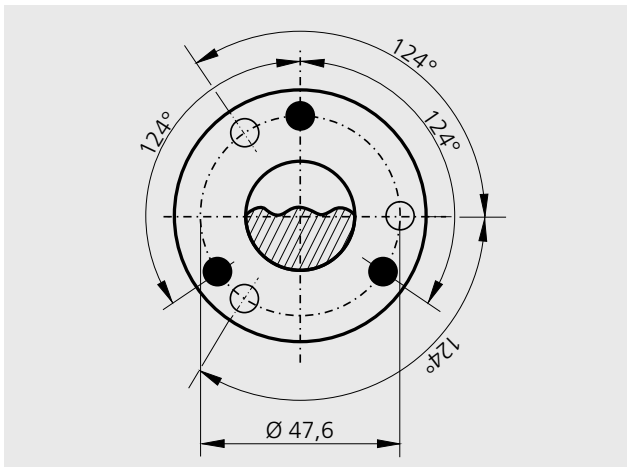

Dimensions in mm

Possibility to connect to oil level regulator

HA44e

- Three-hole connection for oil level regulator of brands ESK, AC+R, CARLY (3 x M6 x 10 deep)
- Three-hole connection for oil level regulator of brand TRAXOIL (3 x M6 x 10 deep)

Dimensions for anti-vibration pad

Type	Ø a	b	Ø c	d
HA22e	40	30	M10	20
HA34e	40	30	M10	20
HA44e	50	30	M12	25

Dimensions in mm

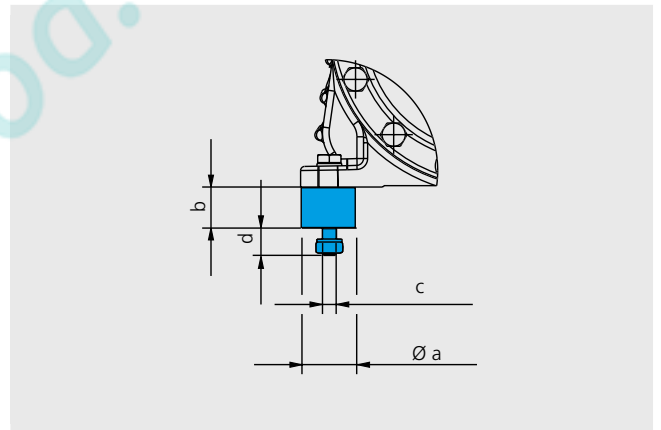

## DIMENSIONS AND CONNECTIONS

Dimensions with accessories

HA22e

HA34e

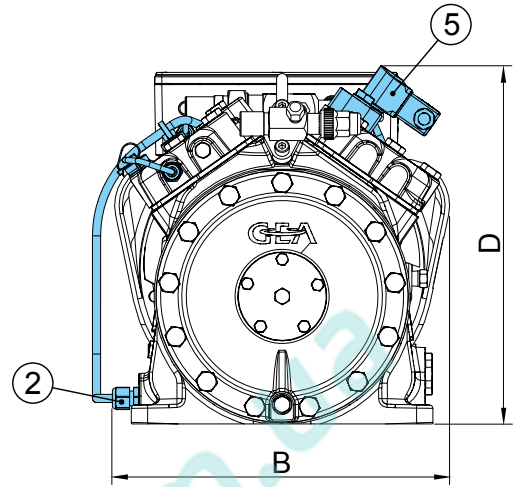
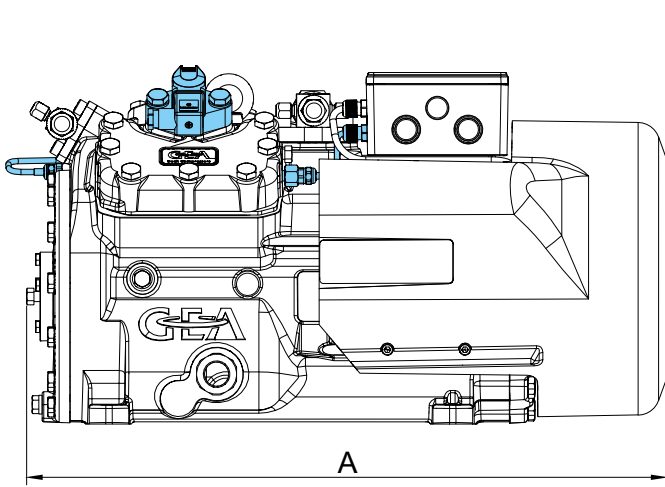

Dimensions with accessories

HA44e

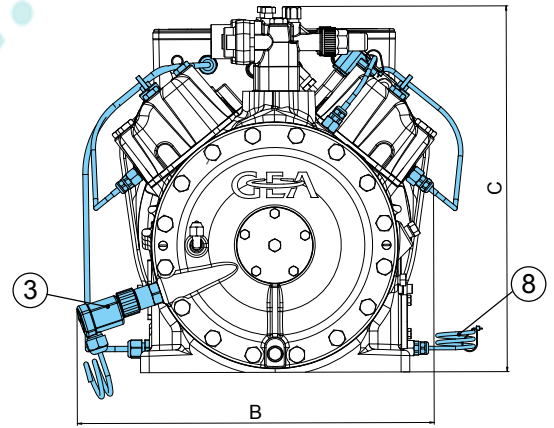
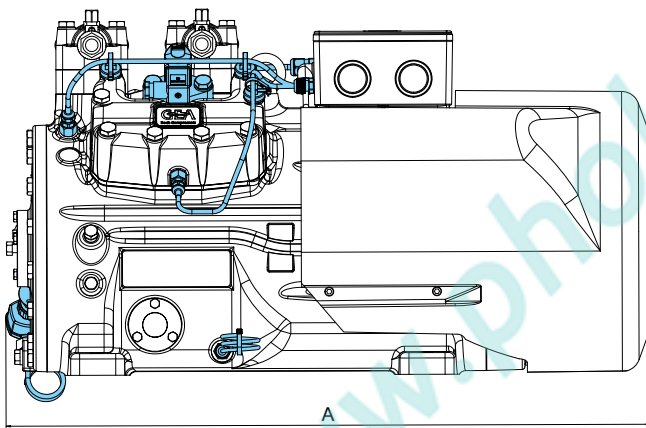

Type	A	B	D
HA22e	ca. 525	ca. 305	–
HA34e	ca. 600	ca. 305	ca. 325
HA44e	ca. 720	ca. 400	ca. 410

Dimensions in mm

Connections		HA22e	HA34e	HA44e
SV	Suction line	please refer to technical data page 28		
DV	Discharge line	please refer to technical data page 28		
A	Connection suction side, not lockable	1/8" NPTF	1/8" NPTF	1/8" NPTF
A1	Connection suction side, lockable	7/16" UNF	7/16" UNF	7/16" UNF
B	Connection discharge side, not lockable	1/8" NPTF	1/8" NPTF	1/8" NPTF
B1	Connection discharge side, lockable	7/16" UNF	7/16" UNF	7/16" UNF
C	Connection oil pressure safety switch HP	1/8" NPTF	1/8" NPTF	1/8" NPTF
D	Connection oil pressure safety switch LP			7/16" UNF
D1	Connection oil return from oil separator	1/4" NPTF	1/4" NPTF	1/4" NPTF
F	Oil drain plug	M 12 x 1,5	M 12 x 1,5	M 12 x 1,5
H	Oil charge plug	1/4" NPTF	1/4" NPTF	1/4" NPTF
J	Connection oil sump heater	3/8" NPTF	3/8" NPTF	3/8" NPTF
K	Sight glass	1 1/8" – 18 UNEF	1 1/8" – 18 UNEF	3 hole M6
L	Connection thermal protection thermostat	1/8" NPTF	1/8" NPTF	1/8" NPTF
M	Oil strainer	M 12 x 1,5	M 12 x 1,5	M 12 x 1,5
O	Connection oil level regulator	1 1/8" – 18 UNEF	1 1/8" – 18 UNEF	3 hole M6
Q	Connection oil temperature sensor			1/8" NPTF

## SCOPE OF SUPPLY &amp; ACCESSORIES

Scope of supply & accessories		HA22e	HA34e	HA44e
	Semi-hermetic two-cylinder reciprocating compressor with drive motor for direct start 220-240 V Δ / 380-420 V Y - 3 - 50 Hz 265-290 V Δ / 440-480 V Y - 3 - 60 Hz	●		
	Semi-hermetic four-cylinder reciprocating compressor with drive motor for direct start 220-240 V Δ / 380-420 V Y - 3 - 50 Hz 265-290 V Δ / 440-480 V Y - 3 - 60 Hz		●	
	Semi-hermetic four-cylinder reciprocating compressor with drive motor for part winding start (50/50) 380-420 V Y/Y - 3 - 50 Hz 440-480 V Y/Y - 3 - 60 Hz Motor unit flanged onto the compressor housing			●
	Special voltage and/or frequency	○ <sup>3)</sup>	○ <sup>3)</sup>	○ <sup>3)</sup>
	Motor is cooled by an integrated fan with air deflection hood 230 V - 1 - 50/60 Hz, IP44 38 W, 0,17 A	●	●	
	Motor is cooled by an integrated fan with air deflection hood 230 V - 1 - 50/60 Hz, IP44 140 W, 0,71 A			●
	Winding protection with PTC resistor sensors with electronic triggering unit INT69 G	●	●	●
1	Thermal protection PTC	○ <sup>2)</sup>	○ <sup>2)</sup>	○ <sup>2)</sup>
	Oil pump	●	●	●
	Oil charge: HA: FUCHS Reniso SP46, HAX: FUCHS Reniso Triton SE55	●	●	●
	Inert gas charge	●	●	●
	4 anti-vibration pads	● <sup>1)</sup>	● <sup>1)</sup>	● <sup>1)</sup>
	Internal safety valve	–	–	●
	Suction and discharge line valve	●	●	●
	Sight glass	●	●	●
2	Oil sump heater 110-240 V - 1 - 50/60 Hz, 50-120 W, ptc heater, self-regulating	○ <sup>2)</sup>	○ <sup>2)</sup>	–
	220-240 V - 1 - 50/60 Hz, 160 W	–	–	○ <sup>2)</sup>
	Rear bearing flange prepared for oil differential pressure sensor	–	–	○ <sup>2)</sup>
3	Oil differential pressure sensor DELTA-P II 220-240 V - 1 - 50/60 Hz	–	–	○ <sup>1)</sup>
	Rear bearing flange prepared for oil differential pressure sensor	–	–	○ <sup>2)</sup>
4	Oil pressure safety switch 230 V - 1 - 50/60 Hz, IP20 MP54	–	–	○ <sup>1)</sup>
	230 V - 1 - 50/60 Hz, IP20 MP55	○ <sup>1)</sup>	○ <sup>1)</sup>	–

● Scope of supply (Standard)  
○ Accessories  
– Not available

<sup>1)</sup> Enclosed  
<sup>2)</sup> Mounted  
<sup>3)</sup> On request



Scope of supply & accessories		HA22e	HA34e	HA44e
5	Capacity regulator 230 V - 1 - 50/60 Hz, IP65 1 capacity regulator = 50 % residual capacity	–	○ <sup>2)</sup>	○ <sup>2)</sup>
6	Prepared for capacity regulator (1 cylinder cover)	–	○ <sup>2)</sup>	○ <sup>2)</sup>
7	Start unloader by means of a ESS (Electronic Soft Start) 400 V - 3 - 50/60 Hz, IP20, (connection clamps IP00) for installation in switch cabinet	○ <sup>1)</sup>	○ <sup>1)</sup>	○ <sup>1)</sup>
8	Oil temperature sensor	–	–	○ <sup>2)</sup>
9	Intermediate flange for suction valve	–	–	○ <sup>1)</sup>
10	INT69 G Diagnose 115 V / 230 V Ac, 50/60 Hz, IP00 (INT69 G not applicable)	○ <sup>2)</sup>	○ <sup>2)</sup>	○ <sup>2)</sup>
11	DP-modbus Gateway 115 V / 230 V Ac, 50/60 Hz, IP00 incl. adapter cable	○ <sup>1)</sup>	○ <sup>1)</sup>	○ <sup>1)</sup>
12	modbus-LAN Gateway 230 V Ac, 50/60 Hz, IP00	○ <sup>1)</sup>	○ <sup>1)</sup>	○ <sup>1)</sup>
13	USB converter for INT69 G Diagnose and INT69 GtML Diagnose	○ <sup>1)</sup>	○ <sup>1)</sup>	○ <sup>1)</sup>
	Connection for oil level regulator of brands ESK, AC+R or CARLY	● <sup>4)</sup>	● <sup>4)</sup>	●
	Connection for oil level regulator of brand Traxoil	● <sup>4)</sup>	● <sup>4)</sup>	● <sup>4)</sup>

● Scope of supply (Standard)  
 ○ Accessories  
 – Not available

<sup>1)</sup> Enclosed  
<sup>2)</sup> Mounted  
<sup>3)</sup> On request  
<sup>4)</sup> Only possible with additional adapter

www.pholod.com.ua

## ACCESSORIES

Thermal protection thermostat

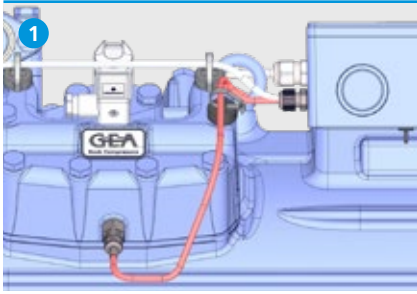

Oil sump heater

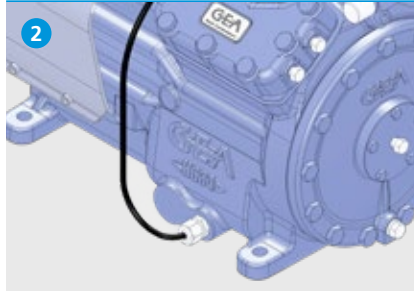

Oil differential pressure sensor

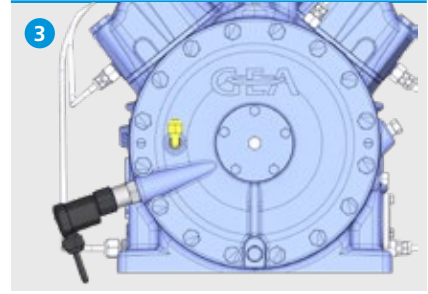

Oil pressure safety switch



Capacity regulator



Prepared for capacity regulator



www.pholod.com

ESS Electronic Soft Start



Oil temperature sensor

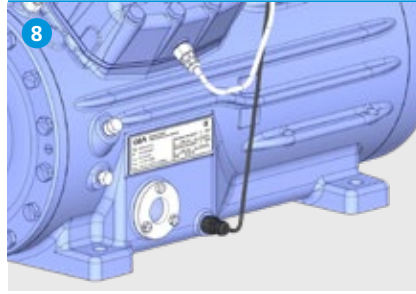

Intermediate flange for suction valve

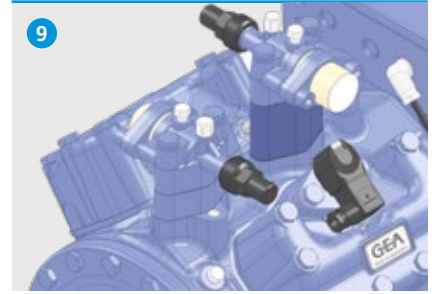

[www.pholod.com.ua](http://www.pholod.com.ua)

ACCESSORIES

INT69 G Diagnose

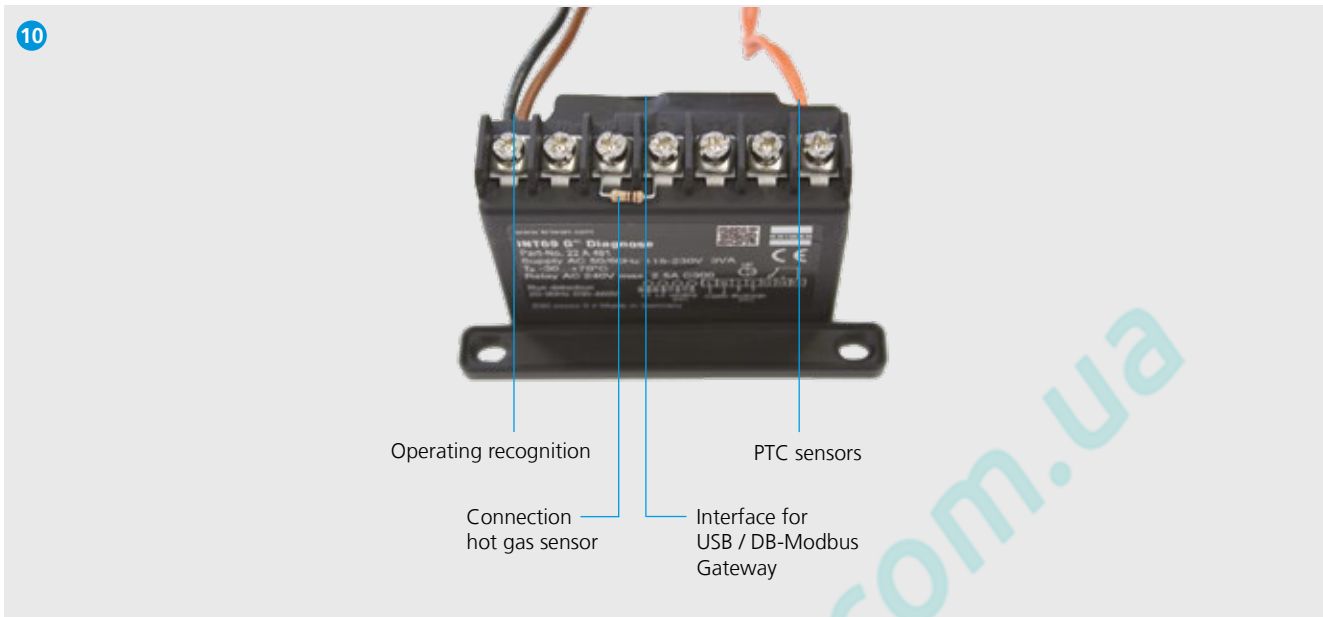

The INT69 G Diagnose also provides the usual functions, such as:

- Motor temperature monitoring
- Hot gas temperature monitoring
- Reconnection preventing device
- Reset function

DP-Modbus Gateway



Modbus-LAN Gateway



USB converter



INT69 G MOTOR PROTECTION

Technical Data

Unit designation	INT69 G (Standard)	INT69 G Diagnose	INT69 GTML Diagnose
Connection voltage	AC 115–230 V - 1- 50/60 Hz ± 10% 3 VA	AC 115–230 V - 1- 50/60 Hz ± 10% 3 VA	AC 115–230 V - 1- 50/60 Hz ± 10% 3 VA
Relay	AC 240 V, 2,5 A, C300	AC 240 V, 2,5 A, C300	AC 240 V, 2,5 A, C300
Dimensions L/W/H	53 × 33 × 68 mm	50 × 33 × 68 mm	87 × 40 × 81.5 mm

**INT69 G Diagnose Unit Motor Protection**

**Read facility via INTelligence diagnosis software**

With the INTelligence software, valuable information can be obtained on the status of the compressor and the system. The diagnosis function includes the plausibility checks of the logic sequences, all important operation and error values of the compressor, and it provides clear visualization. Crucial evaluation parameters can be configured individually. This allows for a quick analysis and an efficient system management.

**Advantages:**

- Simple operation
- Immediate diagnosis and precise problem solving
- Specially adaptable to the user's needs

If required, data can be retrieved directly at each compressor via USB port. A Modbus interface is available for integration in a network. The data is sent periodically via the DP-Modbus gateway and the Modbus-LAN gateway to a server and can be retrieved remotely by the INTelligence diagnosis software. The INTelligence diagnosis software can be downloaded for free at [www.kriwan.com](http://www.kriwan.com).

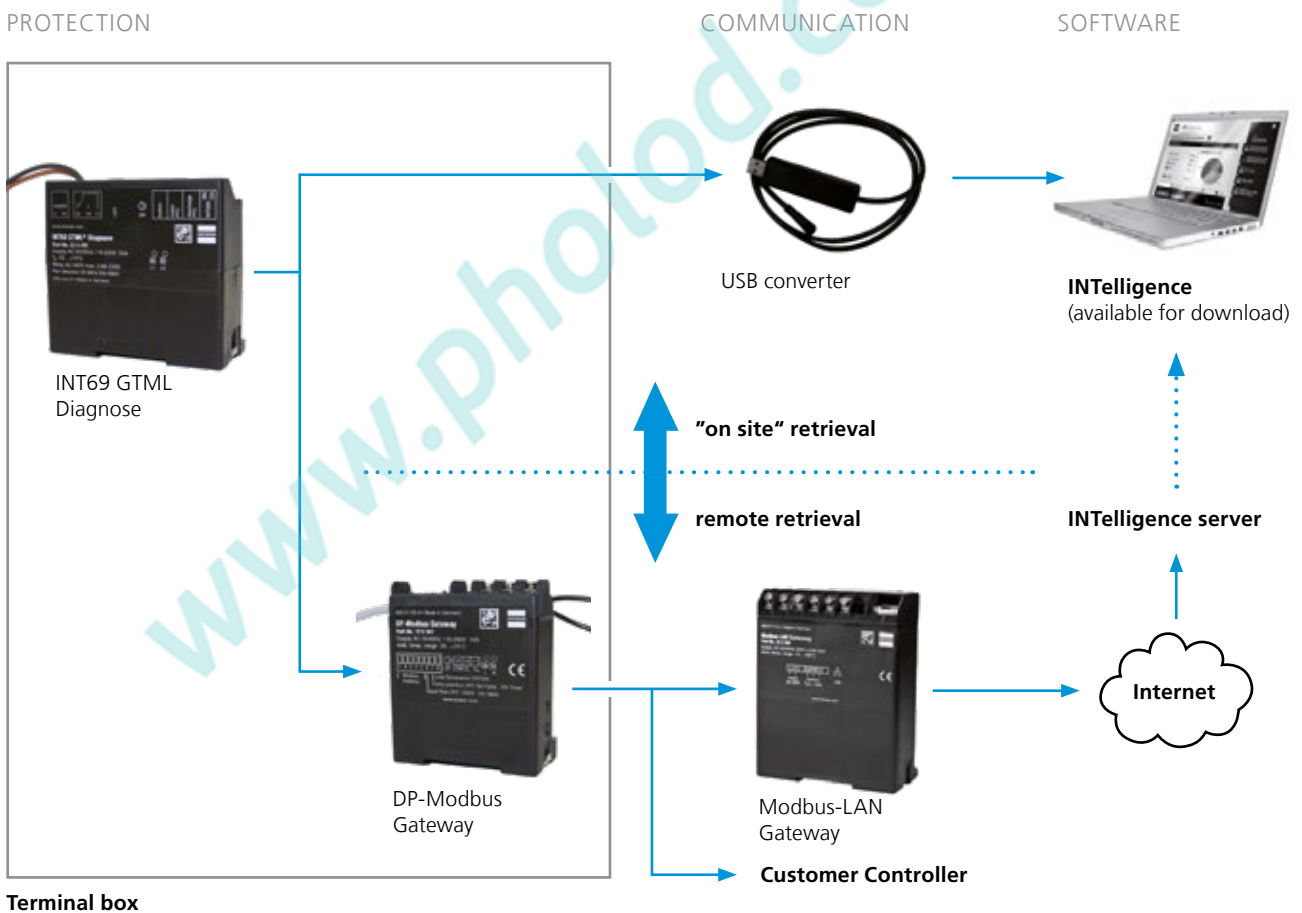





# GEA Service – Because you never stop learning

GEA training and workshops for  
commercial compressors

For many years, GEA has intensified its commitment in the area of customer training.

We offer a comprehensive array of attractive training events, from two-day practitioners' workshops in Frickenhausen to after-work workshops throughout Germany, regardless of the type of training you are interested in.

Three things are characteristic of all GEA trainings:

- The captivating way that the training team carries out the events
- The strong practice orientation of the training events, and
- The fact that all training event from GEA for commercial compressors are offered as a free service

## Overview of training events offered:

- GEA Practitioners' Workshop
- Training tailored to your individual needs
- Training for your entire staff
- Training on your premises

For additional questions or advice, please contact our training center:

Telephone +49 70 22 / 94 54-0

E-Mail: [info@gea.com](mailto:info@gea.com)



# GEA compressors online



## VAP Compressor selection program

The GEA Bock compressor selection software supports you in searching the suitable compressor or condensing unit for your application. On the basis of the entered refrigerating capacity and operating conditions (refrigerant, evaporation and condensing temperature) suitable compressors will be found. Furthermore the software provides additional information on the chosen compressor:

- Operating limits
- Technical data
- Performance data
- Scope of supply and accessories
- Dimensions and connections
- Product image
- Spare part list, drawings, 3D model etc.

The compressor selection program is available as web-based online-version as well as offline-version for installation on the computer.

- Find suitable compressors quickly
- Software update on a daily basis
- For stationary and mobile applications
- All compressors in one version

## Here is the direct way to the online-version:

- GEA Bock HG compressors
- GEA Bock F compressors
- GEA Bock FK compressors



## SOCIAL MEDIA

GEA is represented in the following social media networks:

### LinkedIn

International exchange and land get connected on LinkedIn.

[www.linkedin.com/groups/GEA-Food-4225307](http://www.linkedin.com/groups/GEA-Food-4225307)

### Facebook

Please contact us and stay updated with all the latest news in the transportation industry.

[www.facebook.com/GEAtransportation](http://www.facebook.com/GEAtransportation)

### YouTube

You can find product videos and animations of GEA on YouTube.

[www.youtube.com/user/theGEAgroup](http://www.youtube.com/user/theGEAgroup)

### Twitter

Follow us on Twitter and be always up-to-date.

[www.twitter.com/GEA\\_Events](http://www.twitter.com/GEA_Events)





## We live our values.

Excellence • Passion • Integrity • Responsibility • GEA-versity

GEA is a global technology company with multi-billion euro sales operations in more than 50 countries. Founded in 1881 the company is one of the largest providers of innovative equipment and process technology. GEA is listed in the STOXX® Europe 600 Index. In addition, the company is included in selected MSCI Global Sustainability Indexes.

### GEA Germany

GEA Bock GmbH

Benzstraße 7

72636 Frickenhausen, Germany

Tel +49 7022 9454-0

Fax +49 7022 9454-137

sales.germany@gea.com

gea.com

www.pholod.com.ua